

Altivar Process

Variable Speed Drives ATV930, ATV950

Installation Manual

12/2016



The information provided in this documentation contains general descriptions and/or technical characteristics of the performance of the products contained herein. This documentation is not intended as a substitute for and is not to be used for determining suitability or reliability of these products for specific user applications. It is the duty of any such user or integrator to perform the appropriate and complete risk analysis, evaluation and testing of the products with respect to the relevant specific application or use thereof. Neither Schneider Electric nor any of its affiliates or subsidiaries shall be responsible or liable for misuse of the information contained herein. If you have any suggestions for improvements or amendments or have found errors in this publication, please notify us.

No part of this document may be reproduced in any form or by any means, electronic or mechanical, including photocopying, without express written permission of Schneider Electric.

All pertinent state, regional, and local safety regulations must be observed when installing and using this product. For reasons of safety and to help ensure compliance with documented system data, only the manufacturer should perform repairs to components.

When devices are used for applications with technical safety requirements, the relevant instructions must be followed.

Failure to use Schneider Electric software or approved software with our hardware products may result in injury, harm, or improper operating results.

Failure to observe this information can result in injury or equipment damage.

© 2016 Schneider Electric. All Rights Reserved.

Table of Contents



	Safety Information	5
	About the Book	9
Chapter 1	Introduction	13
	Verifying the Absence of Voltage	14
	Drive Overview	15
	Accessories and Options	24
	Steps for setting up the drive	26
	Preliminary Instructions	27
Chapter 2	Technical Data	31
2.1	Environment Data	32
	Temperature Conditions	33
	Altitude Conditions	34
	Chemical and Mechanical Conditions	34
2.2	Mechanical Data	35
	Dimensions and Weights	35
2.3	Electrical Data	53
	Drive Ratings In Normal Duty	54
	Drive Ratings In Heavy Duty	58
Chapter 3	Drive Mounting	63
	Mounting Conditions	64
	Derating Curves	72
	Mounting Procedures	80
Chapter 4	Drive wiring	85
	Wiring Instructions	86
	Specific Wiring Instructions For Wall Mounting Drives	88
	Specific Wiring Instructions For Floor Standing Drives	89
	Dimensioning Of Power Part Cables For Floor Standing Drives	90
	Cable Length Instructions	92
	Wiring Diagrams	94
	Sink / Source Switch Configuration	97
	Pulse Train Output / Digital Output Switch Configuration	98
	Characteristics of the Power Part Terminals	99
	Wiring the Power Part	106
	Electromagnetic Compatibility	119
	Operation on an IT or Corner Grounded System	121
	Disconnecting The Built-in EMC Filter	121
	Control Terminals Electrical Data	126
	Arrangement and Characteristics of Control Block Terminals and Communication and I/O Ports	129
	Wiring The Control Part	131
Chapter 5	Checking Installation	137
	Before Switching On	137
Chapter 6	Maintenance	139
	Scheduled servicing	139
Glossary	141



Important Information

NOTICE

Read these instructions carefully, and look at the equipment to become familiar with the device before trying to install, operate, service, or maintain it. The following special messages may appear throughout this documentation or on the equipment to warn of potential hazards or to call attention to information that clarifies or simplifies a procedure.



The addition of this symbol to a “Danger” or “Warning” safety label indicates that an electrical hazard exists which will result in personal injury if the instructions are not followed.



This is the safety alert symbol. It is used to alert you to potential personal injury hazards. Obey all safety messages that follow this symbol to avoid possible injury or death.

DANGER

DANGER indicates a hazardous situation which, if not avoided, **will result in** death or serious injury.

WARNING

WARNING indicates a hazardous situation which, if not avoided, **could result in** death or serious injury.

CAUTION

CAUTION indicates a hazardous situation which, if not avoided, **could result in** minor or moderate injury.

NOTICE

NOTICE is used to address practices not related to physical injury.

PLEASE NOTE

Electrical equipment should be installed, operated, serviced, and maintained only by qualified personnel. No responsibility is assumed by Schneider Electric for any consequences arising out of the use of this material.

A qualified person is one who has skills and knowledge related to the construction and operation of electrical equipment and its installation, and has received safety training to recognize and avoid the hazards involved.

Qualification Of Personnel

Only appropriately trained persons who are familiar with and understand the contents of this manual and all other pertinent product documentation are authorized to work on and with this product. In addition, these persons must have received safety training to recognize and avoid hazards involved. These persons must have sufficient technical training, knowledge and experience and be able to foresee and detect potential hazards that may be caused by using the product, by changing the settings and by the mechanical, electrical and electronic equipment of the entire system in which the product is used. All persons working on and with the product must be fully familiar with all applicable standards, directives, and accident prevention regulations when performing such work.

Intended Use

This product is a drive for three-phase synchronous, asynchronous motors and intended for industrial use according to this manual. The product may only be used in compliance with all applicable safety standard and local regulations and directives, the specified requirements and the technical data. The product must be installed outside the hazardous ATEX zone. Prior to using the product, you must perform a risk assessment in view of the planned application. Based on the results, the appropriate safety measures must be implemented. Since the product is used as a component in an entire system, you must ensure the safety of persons by means of the design of this entire system (for example, machine design). Any use other than the use explicitly permitted is prohibited and can result in hazards. Electrical equipment should be installed, operated, serviced, and maintained only by qualified personnel.

Product Related Information

Read and understand these instructions before performing any procedure with this drive.

DANGER

HAZARD OF ELECTRIC SHOCK, EXPLOSION OR ARC FLASH

- Only appropriately trained persons who are familiar with and understand the contents of this manual and all other pertinent product documentation and who have received safety training to recognize and avoid hazards involved are authorized to work on and with this drive system. Installation, adjustment, repair and maintenance must be performed by qualified personnel.
- The system integrator is responsible for compliance with all local and national electrical code requirements as well as all other applicable regulations with respect to grounding of all equipment.
- Many components of the product, including the printed circuit boards, operate with mains voltage. Do not touch.
- Only use properly rated, electrically insulated tools and measuring equipment.
- Do not touch unshielded components or terminals with voltage present.
- Motors can generate voltage when the shaft is rotated. Prior to performing any type of work on the drive system, block the motor shaft to prevent rotation.
- AC voltage can couple voltage to unused conductors in the motor cable. Insulate both ends of unused conductors of the motor cable.
- Do not short across the DC bus terminals or the DC bus capacitors or the braking resistor terminals.
- Before performing work on the drive system:
 - Disconnect all power, including external control power that may be present.
 - Place a **Do Not Turn On** label on all power switches related to the drive system.
 - Lock all power switches in the open position.
 - Wait 15 minutes to allow the DC bus capacitors to discharge.
 - Follow the instructions given in the chapter "Verifying the Absence of Voltage" in the installation manual of the product.
- Before applying voltage to the drive system:
 - Verify that the work has been completed and that the entire installation cannot cause hazards.
 - If the mains input terminals and the motor output terminals have been grounded and short-circuited, remove the ground and the short circuits on the mains input terminals and the motor output terminals.
 - Verify proper grounding of all equipment.
 - Verify that all protective equipment such as covers, doors, grids is installed and/or closed.

Failure to follow these instructions will result in death or serious injury.

NOTE: Refer to the Wiring the Power Part section for the location of DC Bus terminals (PA/+, PC/-).

Drive systems may perform unexpected movements because of incorrect wiring, incorrect settings, incorrect data or other errors.

WARNING

UNANTICIPATED EQUIPMENT OPERATION

- Carefully install the wiring in accordance with the EMC requirements.
- Do not operate the product with unknown or unsuitable settings or data.
- Perform a comprehensive commissioning test.

Failure to follow these instructions can result in death, serious injury, or equipment damage.

Damaged products or accessories may cause electric shock or unanticipated equipment operation.

DANGER

ELECTRIC SHOCK OR UNANTICIPATED EQUIPMENT OPERATION

Do not use damaged products or accessories.

Failure to follow these instructions will result in death or serious injury.

Contact your local Schneider Electric sales office if you detect any damage whatsoever.

WARNING

LOSS OF CONTROL

- The designer of any control scheme must consider the potential failure modes of control paths and, for critical control functions, provide a means to achieve a safe state during and after a path failure. Examples of critical control functions are emergency stop, overtravel stop, power outage and restart.
- Separate or redundant control paths must be provided for critical control functions.
- System control paths may include communication links. Consideration must be given to the implications of unanticipated transmission delays or failures of the link.
- Observe all accident prevention regulations and local safety guidelines (1).
- Each implementation of the product must be individually and thoroughly tested for proper operation before being placed into service.

Failure to follow these instructions can result in death, serious injury, or equipment damage.

(1) For USA: Additional information, refer to NEMA ICS 1.1 (latest edition), Safety Guidelines for the Application, Installation, and Maintenance of Solid State Control and to NEMA ICS 7.1 (latest edition), Safety Standards for Construction and Guide for Selection, Installation and Operation of Adjustable-Speed Drive Systems.

NOTICE

DESTRUCTION DUE TO INCORRECT MAINS VOLTAGE

Before switching on and configuring the product, verify that it is approved for the mains voltage

Failure to follow these instructions can result in equipment damage.

The temperature of the products described in this manual may exceed 80 °C (176 °F) during operation.

WARNING

HOT SURFACES

- Ensure that any contact with hot surfaces is avoided.
- Do not allow flammable or heat-sensitive parts in the immediate vicinity of hot surfaces.
- Verify that the product has sufficiently cooled down before handling it.
- Verify that the heat dissipation is sufficient by performing a test run under maximum load conditions.

Failure to follow these instructions can result in death, serious injury, or equipment damage.

This equipment has been designed to operate outside of any hazardous location. Only install this equipment in zones known to be free of a hazardous atmosphere.

DANGER

POTENTIAL FOR EXPLOSION

Install and use this equipment in non-hazardous locations only.

Failure to follow these instructions will result in death or serious injury.

About the Book



At a Glance

Document Scope

The purpose of this document is:

- to give you mechanical and electrical information related to the Altivar Process drive,
- to show you how to install and wire this drive.

Validity Note

NOTE: The products listed in the document are not all available at the time of publication of this document online. The data, illustrations and product specifications listed in the guide will be completed and updated as the product availabilities evolve. Updates to the guide will be available for download once products are released on the market.

This documentation is valid for the Altivar Process drive.

The technical characteristics of the devices described in this document also appear online. To access this information online:

Step	Action
1	Go to the Schneider Electric home page www.schneider-electric.com .
2	In the Search box type the reference of a product or the name of a product range. <ul style="list-style-type: none">● Do not include blank spaces in the reference or product range.● To get information on grouping similar modules, use asterisks (*).
3	If you entered a reference, go to the Product Datasheets search results and click on the reference that interests you. If you entered the name of a product range, go to the Product Ranges search results and click on the product range that interests you.
4	If more than one reference appears in the Products search results, click on the reference that interests you.
5	Depending on the size of your screen, you may need to scroll down to see the data sheet.
6	To save or print a data sheet as a .pdf file, click Download XXX product datasheet .

The characteristics that are presented in this manual should be the same as those characteristics that appear online. In line with our policy of constant improvement, we may revise content over time to improve clarity and accuracy. If you see a difference between the manual and online information, use the online information as your reference.

Related Documents

Use your tablet or your PC to quickly access detailed and comprehensive information on all our products on www.schneider-electric.com

The internet site provides the information you need for products and solutions

- The whole catalog for detailed characteristics and selection guides
- The CAD files to help design your installation, available in over 20 different file formats
- All software and firmware to maintain your installation up to date
- A large quantity of White Papers, Environment documents, Application solutions, Specifications... to gain a better understanding of our electrical systems and equipment or automation
- And finally all the User Guides related to your drive, listed below:

Title of Documentation	Reference Number
ATV900 Getting Started	NHA61578 (English), NHA61579 (French), NHA61580 (German), NHA61581 (Spanish), EAV61724 (Italian), NHA61583 (Chinese)
ATV900 Getting Started Annex (SCCR)	NHA61584 (English)
ATV930, ATV950 Installation Manual	NHA80932 (English), NHA80933 (French), NHA80934 (German), NHA80935 (Spanish), NHA80936 (Italian), NHA80937 (Chinese)
ATV900 Programming Manual	NHA80757 (English), NHA80758 (French), NHA80759 (German), NHA80760 (Spanish), NHA80761 (Italian), NHA80762 (Chinese)
ATV900 Modbus Serial Link manual (Embedded)	NHA80939 (English)
ATV900 Ethernet manual (Embedded)	NHA80940 (English)
ATV900 PROFIBUS DP manual (VW3A3607)	NHA80941 (English)
ATV900 DeviceNet manual (VW3A3609)	NHA80942 (English)
ATV900 PROFINET manual (VW3A3627)	NHA80943 (English)
ATV900 CANopen manual (VW3A3608, 618, 628)	NHA80945 (English)
ATV900 EtherCAT manual - (VW3A3601)	NHA80946 (English)
ATV900 Communication Parameters	NHA80944 (English)
ATV900 Service Instructions	NHA80954 (English)
Drive Systems ATV960, ATV980 – Installation manual	NHA37118 (German), NHA37119 (English), NHA37121 (French), NHA37122 (Spanish), NHA37123 (Italian), NHA37124 (Dutch), NHA37126 (Polish), NHA37127 (Portuguese), NHA37128 (Russian), NHA37129 (Turkish), NHA37130 (Chinese)
ATV960 Configuration guide	NHA37115 (English), NHA37114 (German)
ATV900 Embedded Safety Function manual	NHA80947 (English)
ATV900 Safety functions manual - VW3A3802	NVE64209 (English), NVE64210 (French), NVE64211 (German), NVE64212 (Spanish), NVE64213 (Italian), NVE64214 (Chinese)
ATV980 Configuration guide	NHA37117 (English), NHA37116 (German)
ATV600F, ATV900F Installation Instruction sheet	NVE57369 (English)
SoMove: FDT	SoMove FDT (English, French, German, Spanish, Italian, Chinese)
Altivar Process ATV900: DTM	ATV9xx DTM Library EN (English), ATV9xx DTM Library FR (French), ATV9xx DTM Language DE (German), ATV9xx DTM Library SP (Spanish), ATV9xx DTM Library IT (Italian), ATV9xx DTM Library CN (Chinese)

You can download these technical publications and other technical information from our website at <http://www.schneider-electric.com/ww/en/download>

Terminology

The technical terms, terminology, and the corresponding descriptions in this manual normally use the terms or definitions in the relevant standards.

In the area of drive systems this includes, but is not limited to, terms such as **error, error message, failure, fault, fault reset, protection, safe state, safety function, warning, warning message**, and so on.

Among others, these standards include:

- IEC 61800 series: Adjustable speed electrical power drive systems
- IEC 61508 Ed.2 series: Functional safety of electrical/electronic/programmable electronic safety-related
- EN 954-1 Safety of machinery - Safety related parts of control systems
- ISO 13849-1 & 2 Safety of machinery - Safety related parts of control systems
- IEC 61158 series: Industrial communication networks - Fieldbus specifications
- IEC 61784 series: Industrial communication networks - Profiles
- IEC 60204-1: Safety of machinery - Electrical equipment of machines – Part 1: General requirements

In addition, the term **zone of operation** is used in conjunction with the description of specific hazards, and is defined as it is for a **hazard zone** or **danger zone** in the EC Machinery Directive (2006/42/EC) and in ISO 12100-1.

Also see the glossary at the end of this manual.

Chapter 1

Introduction

What Is in This Chapter?

This chapter contains the following topics:

Topic	Page
Verifying the Absence of Voltage	14
Drive Overview	15
Accessories and Options	24
Steps for setting up the drive	26
Preliminary Instructions	27

Verifying the Absence of Voltage

Instructions

The DC bus voltage level is determined by measuring the voltage between the DC bus terminals PA/+ and PC/-.

The location of the DC bus terminals depends on the drive model.

Identify your drive model by referring to the nameplate of the drive. Then, refer to the chapter "Wiring the Power Part" (*see page 106*) for the location of the DC bus terminals PA/+ and PC/-.

DANGER

HAZARD OF ELECTRIC SHOCK, EXPLOSION OR ARC FLASH

- Only appropriately trained persons who are familiar with and understand the contents of this manual and all other pertinent product documentation and who have received safety training to recognize and avoid hazards involved are authorized to work on and with this drive system. Installation, adjustment, repair and maintenance must be performed by qualified personnel.
- The system integrator is responsible for compliance with all local and national electrical code requirements as well as all other applicable regulations with respect to grounding of all equipment.
- Many components of the product, including the printed circuit boards, operate with mains voltage. Do not touch.
- Only use properly rated, electrically insulated tools and measuring equipment.
- Do not touch unshielded components or terminals with voltage present.
- Motors can generate voltage when the shaft is rotated. Prior to performing any type of work on the drive system, block the motor shaft to prevent rotation.
- AC voltage can couple voltage to unused conductors in the motor cable. Insulate both ends of unused conductors of the motor cable.
- Do not short across the DC bus terminals or the DC bus capacitors or the braking resistor terminals.
- Before performing work on the drive system:
 - Disconnect all power, including external control power that may be present.
 - Place a **Do Not Turn On** label on all power switches related to the drive system.
 - Lock all power switches in the open position.
 - Wait 15 minutes to allow the DC bus capacitors to discharge.
 - Follow the instructions given in the chapter "Verifying the Absence of Voltage" in the installation manual of the product.
- Before applying voltage to the drive system:
 - Verify that the work has been completed and that the entire installation cannot cause hazards.
 - If the mains input terminals and the motor output terminals have been grounded and short-circuited, remove the ground and the short circuits on the mains input terminals and the motor output terminals.
 - Verify proper grounding of all equipment.
 - Verify that all protective equipment such as covers, doors, grids is installed and/or closed.

Failure to follow these instructions will result in death or serious injury.

Procedure



Perform the following actions to verify the absence of voltage

Step	Action
1	Measure the voltage on the DC bus between the DC bus terminals (PA/+ and PC/-) using a properly rated voltmeter to verify that the voltage is less than 42 Vdc
2	If the DC bus capacitors do not discharge properly, contact your local Schneider Electric representative. Do not repair or operate the product.
3	Verify that no other voltage is present in the drive system.

Drive Overview

Frame Sizes for IP21 Products - Wall Mounting

The family of Altivar Process includes 7 frame sizes for IP21 products.

Frame size 1	Frame size 2
<ul style="list-style-type: none"> • 3-phase 200...240 V, 0.75...4 kW, 1...5 HP • 3-phase 380...480 V, 0.75...5.5 kW, 1...7 1/2 HP 	<ul style="list-style-type: none"> • 3-phase 200...240 V, 5.5 kW, 7 1/2 HP • 3-phase 380...480 V, 7.5...11 kW, 10...15 HP
	
ATV930U07M3...U40M3, ATV930U07N4...U55N4	ATV930U55M3, ATV930U75N4, ATV930D11N4

Frame size 3	Frame size 4
<ul style="list-style-type: none"> • 3-phase 200...240 V, 7.5 kW, 10 HP, 11 kW, 15 HP • 3-phase 380...480 V, 15...22 kW, 20...30 HP 	<ul style="list-style-type: none"> • 3-phase 200...240 V 15...22 kW, 20...30 HP • 3-phase 380...480 V, 30...45 kW, 40...60 HP
	
ATV930U75M3, ATV930D11M3, ATV930D15N4...D22N4	ATV930D15M3...ATV930D22M3, ATV930D30N4...ATV930D45N4

Frame size 5	Frame size 6
<ul style="list-style-type: none"> ● 3-phase 200...240 V, 30...45 kW, 40...60 HP ● 3-phase 380...480 V, 55...90 kW, 75...125 HP 	<ul style="list-style-type: none"> ● 3-phase 200...240 V, 55 and 75 kW, 75...100 HP ● 3-phase 380...480 V, 110...160 kW, 150...250 HP
	
<p>ATV930D30M3...D45M3, ATV930D55N4...D90N4, ATV930D30M3C...D45M3C, ATV930D55N4C...D90N4C (1)</p>	<p>ATV930D55M3C, ATV930D75M3C, ATV930C11N4C...C16N4C,</p>
<p>(1) The letter C indicates a drive without braking unit. Braking units are available as an external option for Frame size 6 drives, see www.schneider-electric.com</p>	



Frame size 7A	Frame size 7B
<ul style="list-style-type: none"> ● 3-phase 380...480 V, 220 kW, 350 HP 	<ul style="list-style-type: none"> ● 3-phase 380...480 V, 250 and 315 kW, 400 and 500 HP
 <p>The image shows a tall, dark blue Schneider Electric drive unit for Frame size 7A. It features a green control panel with a digital display and buttons. The unit is mounted on a grey metal frame. The Schneider logo is visible at the bottom.</p>	 <p>The image shows a taller, dark blue Schneider Electric drive unit for Frame size 7B. It has a similar design to the 7A unit, with a green control panel and a digital display. The Schneider logo is visible at the bottom.</p>
ATV930C22N4, ATV930C22N4C (1)	ATV930C25N4C, ATV930C31N4C (1)
<p>(1) The letter C indicates a drive without braking unit. Braking units are available as an external option for Frame size 7 drives, see www.schneider-electric.com</p>	

Frame Sizes for IP55 Products - Wall Mounting

The family of Altivar Process includes 3 frame sizes for IP55 products, with or without integrated load switch.

Frame size A
<ul style="list-style-type: none">3-phase 380...480 V, 0.75...22 kW, 1...30 HP, with or without Vario load switch

ATV950U07N4(E)*...U75N4(E)*, ATV950D11N4(E)*...D22N4(E)*
(E)*= product included a Vario load switch

Frame size B	Frame size C
<ul style="list-style-type: none"> 3-phase 380...480 V, 30...45 kW, 40...60 HP, with or without Vario load switch 	<ul style="list-style-type: none"> 3-phase 380...480 V, 55...90 kW, 75...125 HP, with or without Vario load switch
	
ATV950D30N4(E)*...D45N4(E)*	ATV950D55N4(E)*...D90N4(E)*
(E)*= product included a Vario load switch	

Frame Sizes for IP21 Products - Floor Standing

NOTE: Please refer to the Service Instructions ([NVE57369](#)) related to drive Systems ATV960, ATV980 Variable Speed Drives ATV930F, ATV950F.

The family of Altivar Process includes 2 frame sizes for IP21 products.

Frame size FS1	Frame size FS2
<ul style="list-style-type: none"> ● 3-phase 380...440 V, 110...160 kW 	<ul style="list-style-type: none"> ● 3-phase 380...440 V, 200...315 kW
 <p>A tall, grey, floor-standing drive unit for Frame size FS1. It features a top-mounted cooling fan, a central green control panel with a digital display, and a bottom-mounted ventilation grille. A yellow warning label is visible on the left side.</p>	 <p>A taller, grey, floor-standing drive unit for Frame size FS2. It features a top-mounted cooling fan, a central green control panel with a digital display, and a bottom-mounted ventilation grille. A yellow warning label is visible on the left side.</p>
ATV930C11N4F...C16N4F	ATV930C20N4F...C31N4F

Frame Sizes for IP54 Products - Floor Standing

The family of Altivar Process includes 2 frame sizes for IP54 products.

Frame size FSA	Frame size FSB
● 3-phase 380...440 V, 110...160 kW	● 3-phase 380...440 V, 200...315 kW
 A tall, grey, floor-standing industrial drive unit. It features a top-mounted cooling fan, a green control panel with a digital display and buttons, a black handle, and a bottom-mounted ventilation grille. The Schneider logo is visible at the top.	 A taller, grey, floor-standing industrial drive unit. It features a top-mounted cooling fan, a green control panel with a digital display and buttons, a black handle, and a bottom-mounted ventilation grille. The Schneider logo is visible at the top.
ATV950C11N4F...C16N4F	ATV950C20N4F...C31N4F

Catalog Number Description









	ATV	950	D	75	N4	E
Product Range	ATV Altivar					
Product Type	930 Standard product 940 AFE product IP21 950 Harsh Environment Wall & floor standing product IP55/IP54 960 Drive System 980 AFE Drive System					
Factor for power rating	U power x 0.1 D power x 1 C power x 10 M power x 100 T power x 1000					
Power rating	07 - 11 - 13 - 15 -16 - 18 - 20 - 22 - 25 - 30 - 31 - 40 - 45 - 55 - 63 - 75 - 90					
Power part supply	M3 200 Vac (200...240 Vac) N4 400 Vac (380...480 Vac) (*)					
Product variants	E ATV950 with load switch (load switch is embedded in floor standing version) F ATV930 & ATV950 floor standing version C ATV930 without braking chopper					

NOTE: see the catalog for possible combinations.

(*) N4F 400 Vac drives voltage: 380...440 Vac

Nameplate example

The nameplate contains the following data:

①	Altivar 930			
②	ATV930U40N4			
③	4kW - 5HP			
④	V1.0 IE00			
⑤		Input	Output	
	kW	U (V~)	380 - 480 Φ 3	0...380 - 480 Φ 3
		F (Hz)	50 / 60	0...500
I (A)		7.6 max	9.3	
⑥	HP	U (V~)	380 - 480 Φ 3	0...380 - 480 Φ 3
		F (Hz)	50 / 60	0...500
		I (A)	7.6 max	9.3
SCCR : for rating and protection refer to Annex of the getting started				
Internal Motor Overload Protection - Class 10				
⑦		Cu AWG14 75° C	IP21	
		15.9 lb.in 1.8 N.m		
⑧	   			
				
⑨				
⑩	6W0502001001			
Made in Indonesia		 FR 92506 Rueil Malmaison		

- ① Product type ② Catalog number ③ Power rating
- ④ Firmware version ⑤ Power part supply
- ⑥ Fuses and overload protection information ⑦ Power part cable information
- ⑧ Degree of protection ⑨ Certifications ⑩ Serial number

Accessories and Options

Introduction

Altivar Process drives are designed to take numerous accessories and options to increase their functionality. For a detailed description and catalog numbers, refer to the Catalog on schneider-electric.com

All accessories and options come with an instruction sheet to help installation and commissioning. Therefore you will only find here a short product description.

Accessories

Drive

- Fan replacement kit
- External braking resistors
- External braking unit for frame size 6

Graphic display terminal

- Remote mounting kit for mounting on enclosure door
- Multidrop connection accessories for connecting several drives to the RJ45 terminal port

Drive mounting kits

- Flush-mounting kit (*see page 65*) for separate air flow

IP upgrade

- Metal conduit box for frame sizes 6, 7a and 7b product for IP21 degree of protection on bottom side

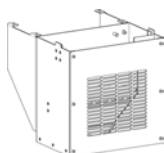

Modbus Communication tools

- Wifi dongle
- Bluetooth dongle
- USB to Modbus adapter

Options

Encoder interfaces modules

- Resolver interface module
- Digital interface encoder module 5/12 V
- Analog interface encoder module

Safety functions module

Additional module support

I/O extension modules

- Digital and analog I/O module
- Relay output module

Communication modules

- CANopen daisy chain
- CANopen SUB-D
- CANopen screw terminal block
- PROFINET
- PROFIBUS DP V1
- DeviceNet
- EtherCAT

Braking units

Braking resistors

Filters

Passive filters

EMC input filters

Output filters

- dv/dt filters
- Sinus filters
- Common mode filters for frame sizes 1...6

Steps for setting up the drive

Procedure

INSTALLATION

① Receive and inspect the drive controller

- Check that the catalog number printed on the label is the same as that on the purchase order
- Remove the drive from its packaging and check that it has not been damaged

② Verify the supply mains

- Verify that the supply mains is compatible with the power part supply range of the drive.

③ Mount the drive

- Mount the drive in accordance with the instructions in this document
- Install the transformer(s), if any
- Install any internal and external options

④ Wire the drive

- Connect the motor, ensuring that its connections correspond to the voltage
- Connect the supply mains, after making sure that the power is off
- Connect the control

Steps 1 to 4 must be performed with the power off.



5 PROGRAMMING

Refer to the Programming Manual

Preliminary Instructions

Handling and Storage

⚠ WARNING	
DANGEROUS HANDLING	
<ul style="list-style-type: none">• Do not handle a damaged packaging.• Follow the handling instructions.• Open and handle the packaging with care.	
Failure to follow these instructions can result in death, serious injury, or equipment damage.	

To help protect the drive before installation, handle and store the device in its packaging. Ensure that the ambient conditions are acceptable.

Check the Delivery of the Drive

Damaged products or accessories may cause electric shock or unanticipated equipment operation.

⚠ ⚠ DANGER	
ELECTRIC SHOCK OR UNANTICIPATED EQUIPMENT OPERATION	
Do not use damaged products or accessories.	
Failure to follow these instructions will result in death or serious injury.	

Contact your local Schneider Electric sales office if you detect any damage whatsoever.

Step	Action
1	Remove the drive from the packaging and verify that it has not been damaged
2	Verify that the catalog number printed on the nameplate (<i>see page 23</i>) corresponds to the purchase order.

Handling the Wall Mounting Drives Up to Frame Size 6

Altivar Process drives of frame size A, and frame sizes 1 up to 3 can be removed from their packaging and installed without a handling device.

Higher frame size drives require a handling device; for this reason, these drives all have lifting lugs.

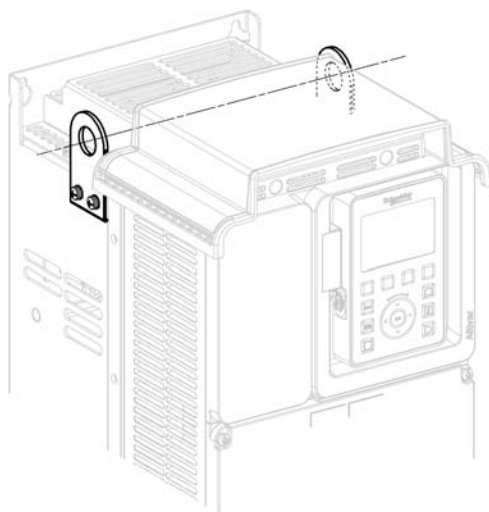

Unpacking the Frame Size 7A and 7B Drives

The drive and the DC choke(s) are mounted on a pallet with screws.

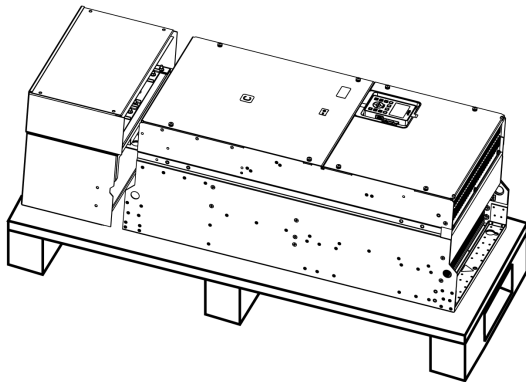

Disassembling the DC Chokes of Frame Size 7A and 7B Drives

CAUTION

SHARP EDGES

The fixing screws that hold the DC chokes support on the pallet are difficult to access, leading to a risk of cutting oneself. Take all possible measures to avoid this risk, and use protective gloves.

Failure to follow these instructions can result in injury or equipment damage.

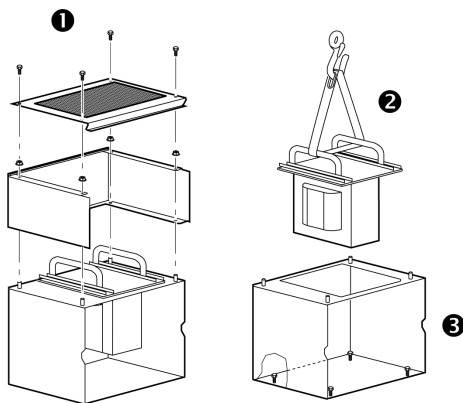

The unit should be disassembled in the following order:

Step	Action
1	Disassemble the components of the DC choke(s) for installation later
2	Remove the DC choke(s) by means of a hoist
3	Remove the fixing screws from the DC choke support and retain them for future use

Hoisting the Frame Size 7A and 7B Drives

⚠ WARNING

RISK OF TOPPLING

Never stand the drive upright without keeping hold of it, or it will topple over.

Failure to follow these instructions can result in death, serious injury, or equipment damage.

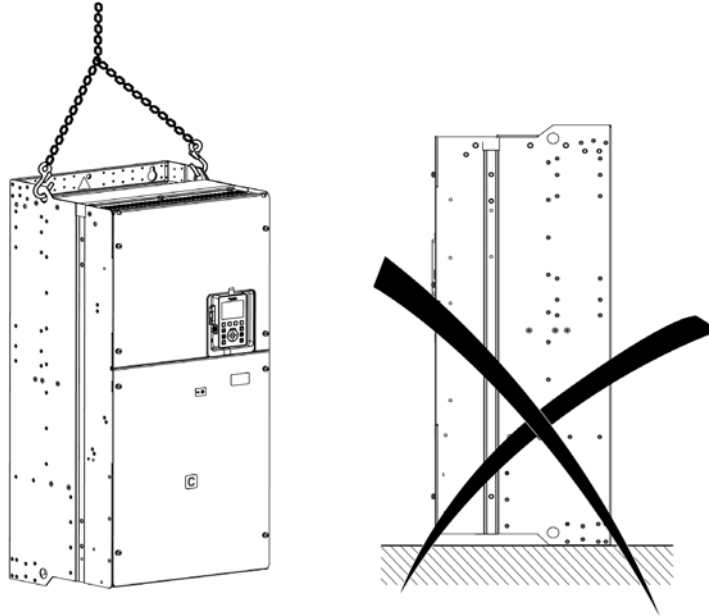

Respect the following instructions to hoist the drive:

Step	Action
1	Remove the screws holding the drive on the pallet
2	Lift off the drive by means of a hoist. It is fitted with handling lugs for this purpose
3	Move the drive to its mounting position, on a wall or the back of the enclosure in accordance with the instructions given in this document, before installing the DC choke (<i>see page 80</i>)

Handling and Hoisting the Floor Standing Drives

⚠ WARNING

RISK OF TOPPLING

The high centre of gravity results in an increased risk of toppling.

Before handling the drive with a forklift, install and tighten straps to ensure a tight connection with the pallet.

Failure to follow these instructions can result in death, serious injury, or equipment damage.

NOTE: Handling, hoisting and installation of the floor standing drives are described in the dedicated instruction sheet [NVE57369](#) delivered with these drives and available on schneider-electric.com.

Chapter 2

Technical Data

What Is in This Chapter?

This chapter contains the following sections:

Section	Topic	Page
2.1	Environment Data	32
2.2	Mechanical Data	35
2.3	Electrical Data	53

Section 2.1 Environment Data

What Is in This Section?

This section contains the following topics:

Topic	Page
Temperature Conditions	33
Altitude Conditions	34
Chemical and Mechanical Conditions	34

Temperature Conditions

Climatic Environmental Conditions for Transportation and Storage

The environment during transportation and storage must be dry and free from dust.

Storage Temperature	Wall mounting drives	°C	-40...70
		°F	-40...158
	Frame sizes 7a and 7b and Floor standing drives	°C	-25...70
		°F	-13...158
Transportation Temperature	Wall mounting drives	°C	-40...70
		°F	-40...158
	Floor standing drives	°C	-25...70
		°F	-13...158
Relative humidity		%	5...95

Climatic Environmental Conditions for Operation

The maximum permissible ambient temperature during operation depends on the mounting distances between the devices and on the required power. Observe the pertinent instructions in the chapter Drive Mounting (*see page 63*).

Frame sizes 1...6 Wall mounting drives	Temperature without derating	°C	-15...50
		°F	5...122
	Temperature with derating of output power (1)	°C	Up to 60
		°F	Up to 140
Frame sizes 7a and 7b Wall mounting drives	Temperature without derating	°C	-10...40
		°F	14...104
	Temperature with derating of output power (1)	°C	Up to 60
		°F	Up to 140
Frame sizes A...C Wall mounting drives	Temperature without derating	°C	-15...40
		°F	5...104
	Temperature with derating of output power (1)	°C	Up to 50
		°F	Up to 122
All frame sizes Floor standing drives	Temperature without derating	°C	0...40
		°F	32...104
	Temperature with derating of output power (1)	°C	Up to 50
		°F	Up to 122
All products	Relative humidity without condensing	%	5...95

(1) Refer to Derating Curves section (*see page 72*).

Altitude Conditions

Operating Altitude

Operating possibilities according to the altitude

Altitude	Supply voltage	Supply Electrical Network			Derating
		TT/TN	IT	Corner-Grounded	
Up to 1000 m (3300 ft)	200..240 V	✓	✓	✓	o
	380..480 V (1)	✓	✓	✓	o
1000...2000 m (3300...6600 ft)	200..240 V	✓	✓	✓	✓
	380..480 V (1)	✓	✓	✓	✓
2000...3800 m (6600...12400 ft)	200..240 V	✓	✓	✓	✓
	380..480 V (1)	✓	✓	-	✓
3800...4800 m (12400...15700 ft)	200..240 V	✓	✓	✓	✓
	380..480 V (1)	✓	-	-	✓

(1) The voltage of floor standing drives ATV**0***N4F is limited to 440 Vac.
Legend:
 ✓: Derate the nominal current of the drive by 1% for each additional 100 m.
 o: Without derating
 -: Not applicable

Chemical and Mechanical Conditions

Withstand to harsh environments

- Chemical class 3C3 conforming to IEC/EN 60721
- Mechanical class 3S3 conforming to IEC/EN 60721

Section 2.2

Mechanical Data

Dimensions and Weights

About the drawings

All drawings CAD files can be downloaded from www.schneider-electric.com

NOTE: When designing your installation, please take into account that all depth values should be increased by 40 mm (1.58 in) in case of using the additional slot option. This option module takes place between the graphic display terminal and the drive, causing the depth value to be increased. It enables to connect a safety output module, an I/O or relay output module.

Frame Size 1

IP21 / UL Type 1 Drives - Side and Front View

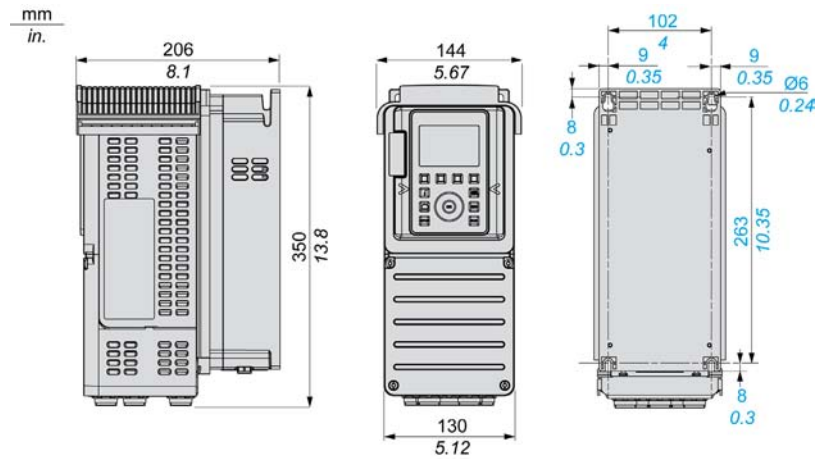

Weights

Catalog Number	Weight in kg (lb)
ATV930U07M3, ATV930U15M3	4.3 (9.5)
ATV930U07N4...U22N4, U22M3...U30M3	4.5 (9.9)
ATV930U30N4, ATV930U40N4, ATV930U40M3	4.6 (10.1)
ATV930U55N4	4.7 (10.4)

Frame size 2

IP21 / UL Type 1 Drives - Side and Front View

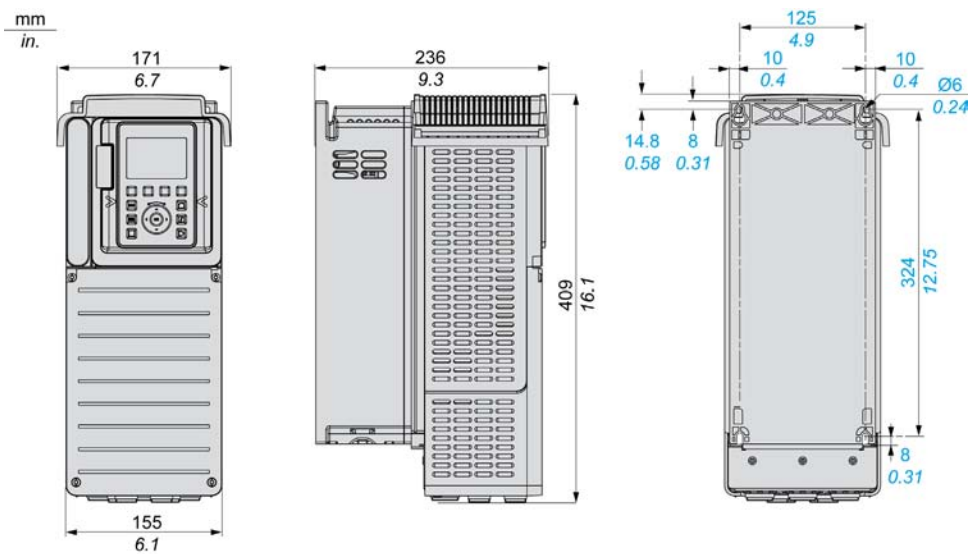

Weights

Catalog Number	Weight in kg (lb)
ATV930U75N4, ATV930D11N4 ATV930U55M3	7.7 (17)

Frame size 3

IP21 / UL Type 1 Drives - Front and Side View

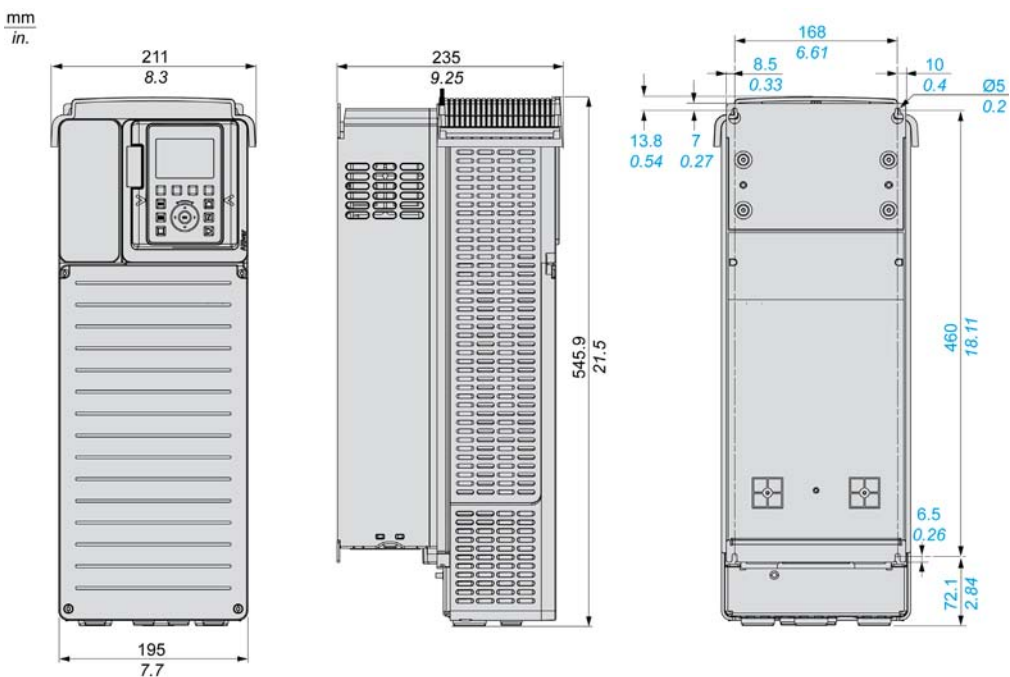

Weights

Catalog Number	Weight in kg (lb)
ATV930U75M3	13.8 (30.4)
ATV930D11M3	13.8 (30.4)
ATV930D15N4	13.6 (30)
ATV930D18N4	14.2 (31.3)
ATV930D22N4	14.3 (31.5)

Frame size 4

IP21 / UL Type 1 Drives - Side, Front and Rear View

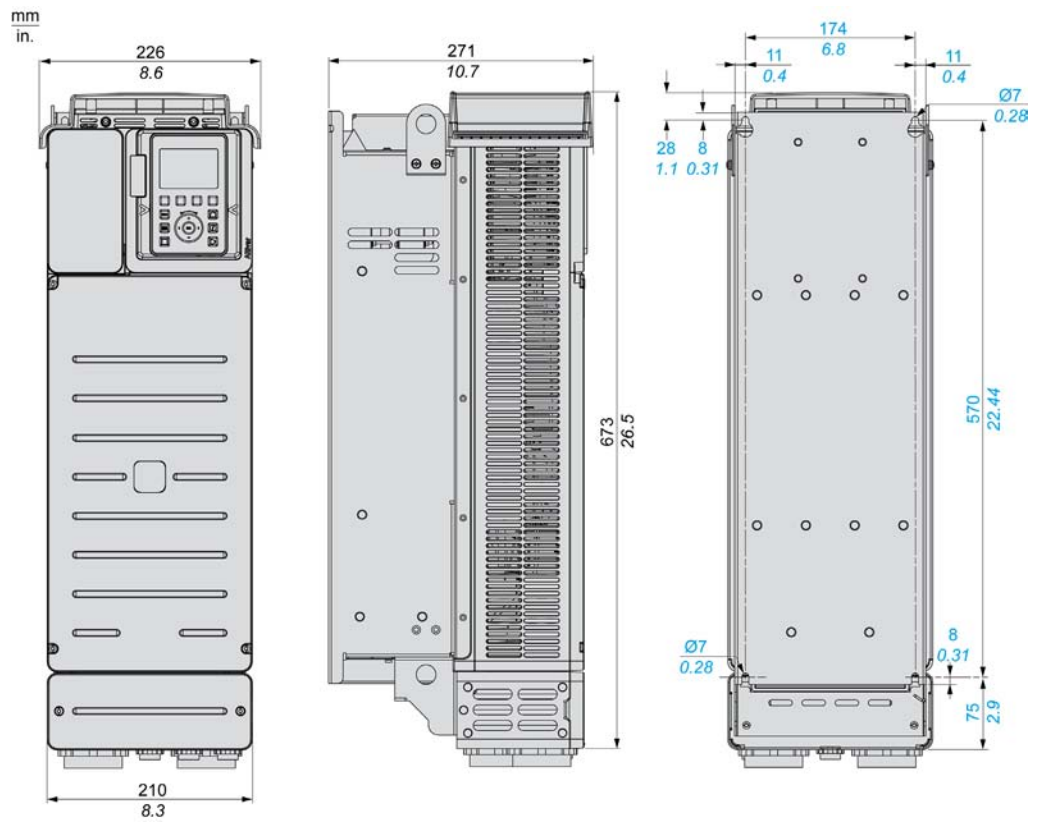

Weights

Catalog Number	Weight in kg (lb)
ATV930D15M3...D22M3	27.3 (60.2)
ATV930D30N4	28 (61.7)
ATV930D37N4	28.2 (62.2)
ATV930D45N4	28.7 (63.3)

Frame size 5

IP21 / UL Type 1 Drives - Side and Front View

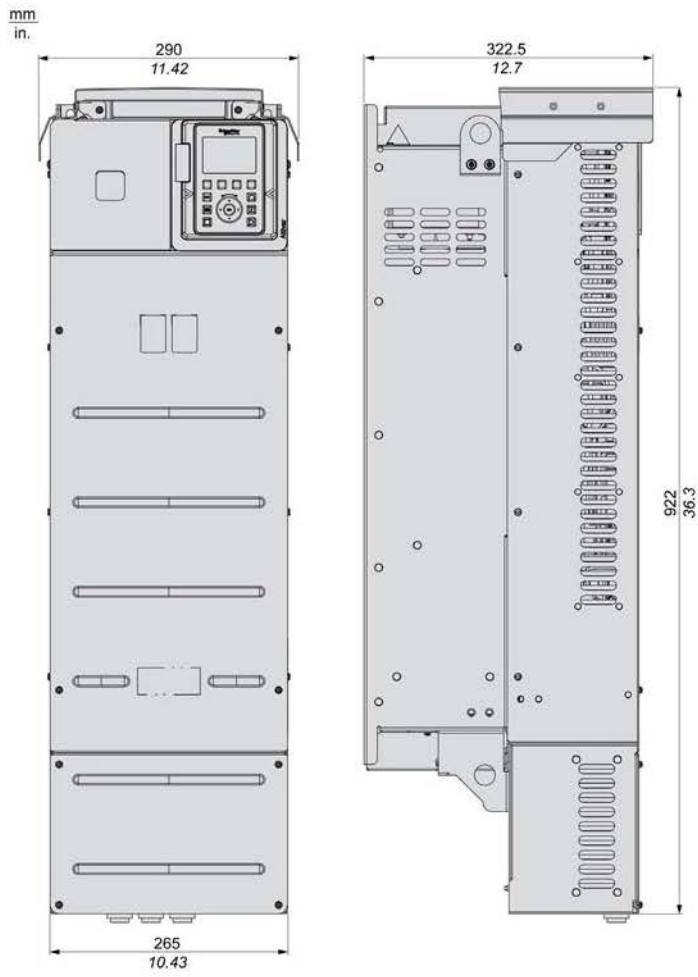

Drives without IP21 top cover - Rear View

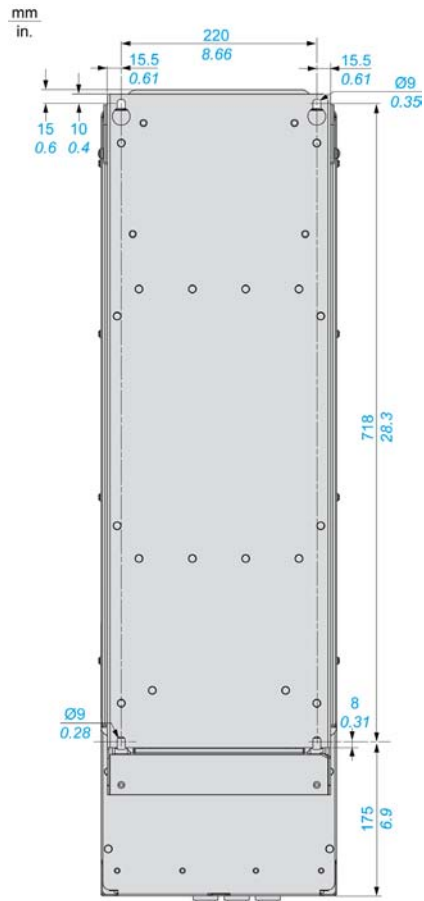

Weights

Catalog Number	Weight in kg (lb)
ATV930D30M3C...D45M3C	57.6 (127)
ATV930D55N4C	56.5 (124.6)
ATV930D75N4C	58 (127.9)
ATV930D90N4C	58.5 (129)
ATV930D30M3...D45M3	57.6 (127)
ATV930D55N4	57.5 (126.8)
ATV930D75N4	59 (130.1)
ATV930D90N4	59.5 (131.2)

Frame size 6

IP21 On Top and IP00 on bottom Drives - Side and Front View

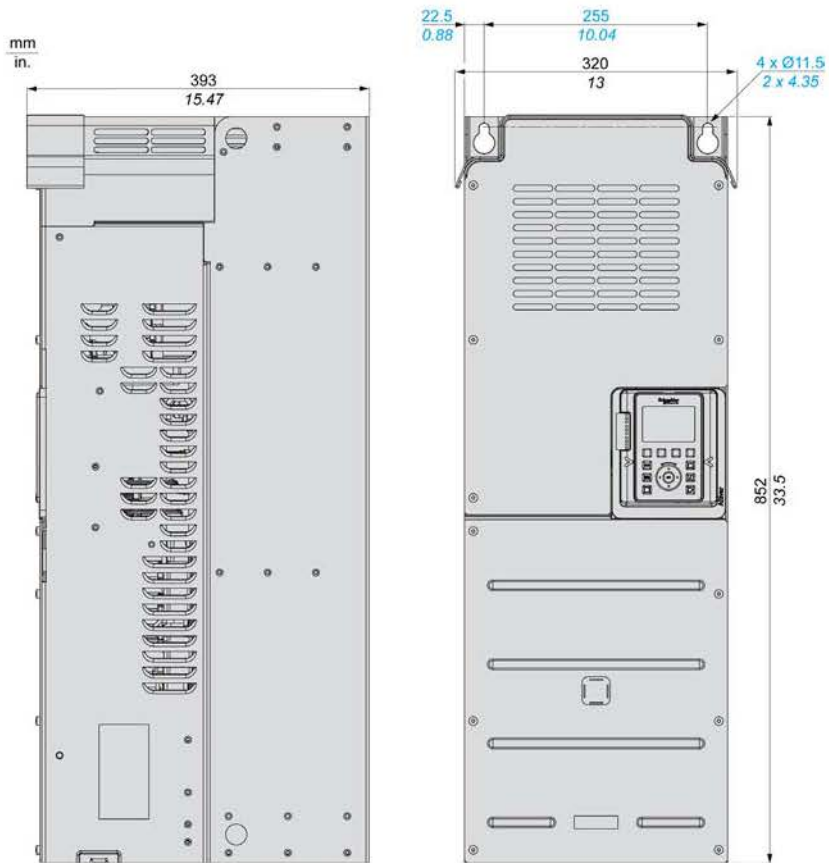

IP21 on Top and Bottom Drives - Rear, Front and Side View

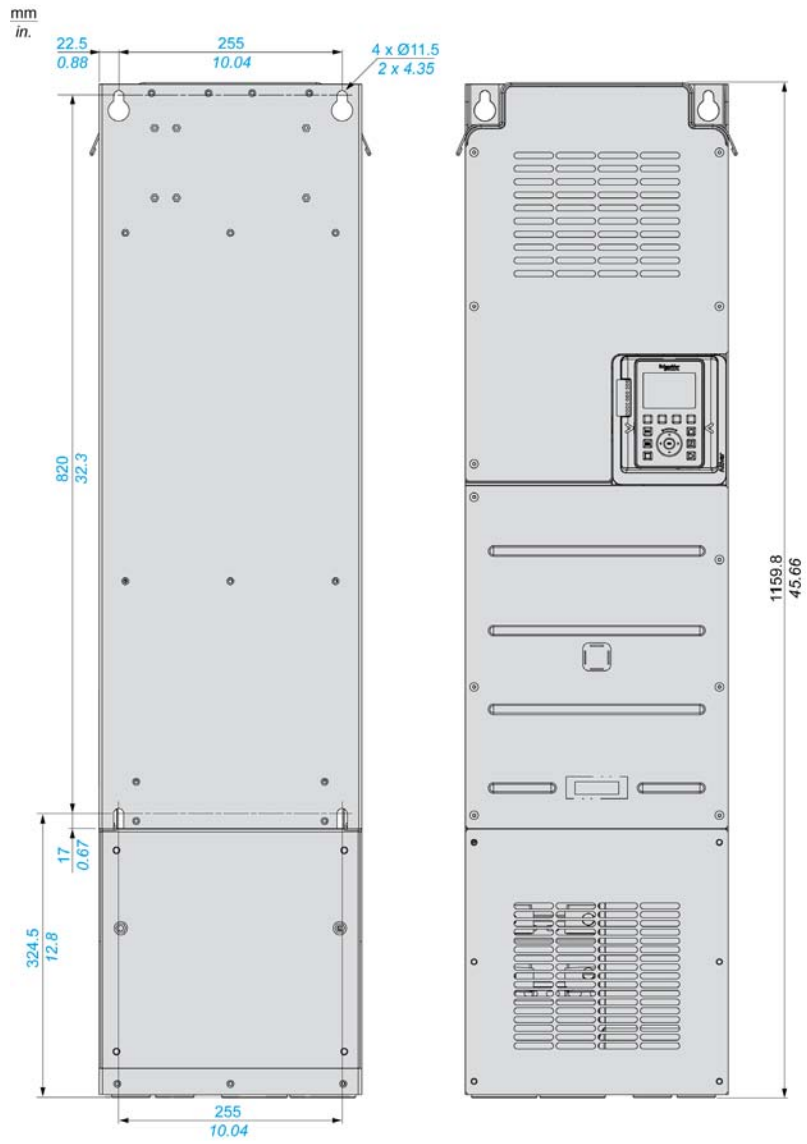

NOTE: Lower Conduit Box part sold separately. This part enables wall mounting of the product. It provides IP21 protection degree on the bottom side and UL type 1 protection degree.

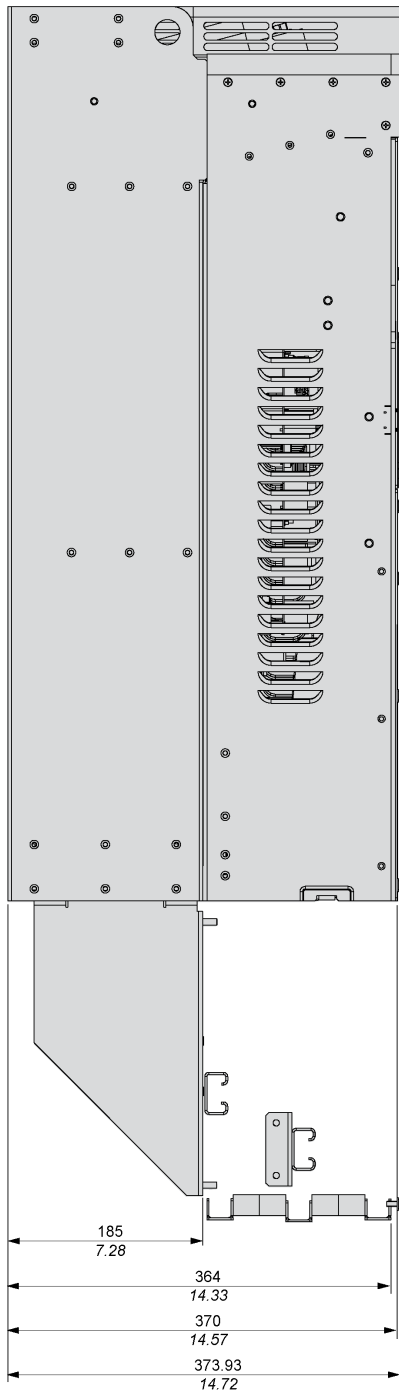

Weights

Catalog Number	Weight in kg (lb)
ATV930C11N4C...ATV930C16N4C	82 (181)
ATV930D55M3C, ATV930D75M3C	80 (176)

Frame Size 7a

ATV930C22N4, ATV930C22N4C

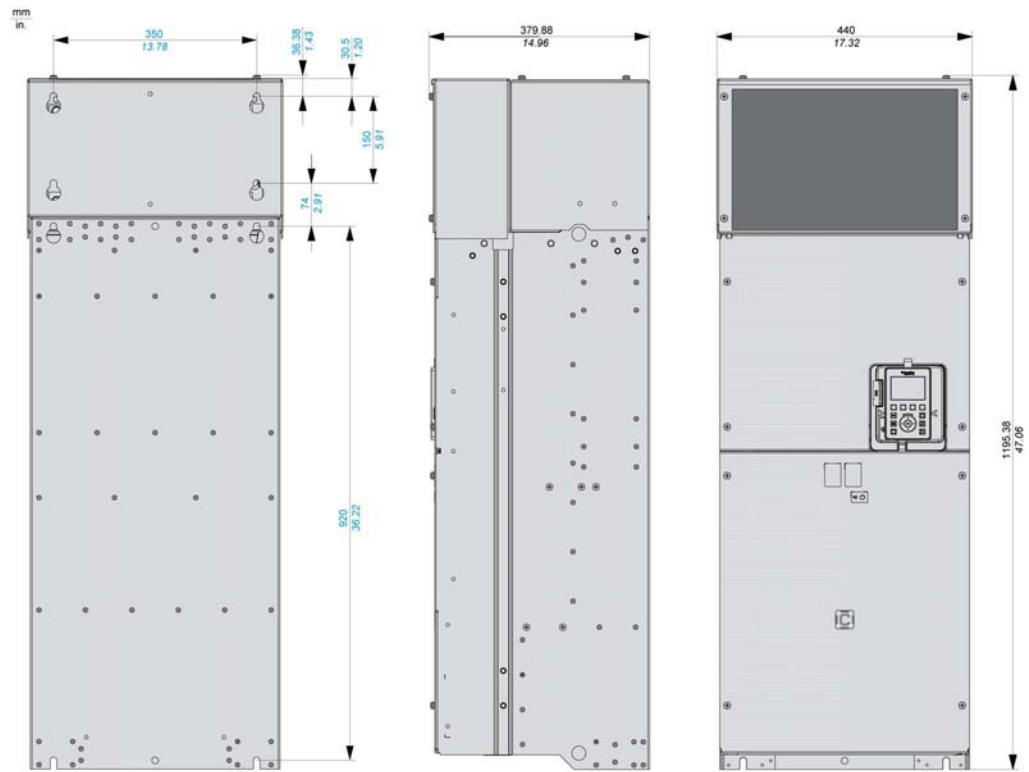

Weights

Catalog Number	Weight in kg (lb)
ATV930C22N4, ATV930C22N4C	172 (379)

Frame Size 7b

ATV930C25N4C, ATV930C31N4C

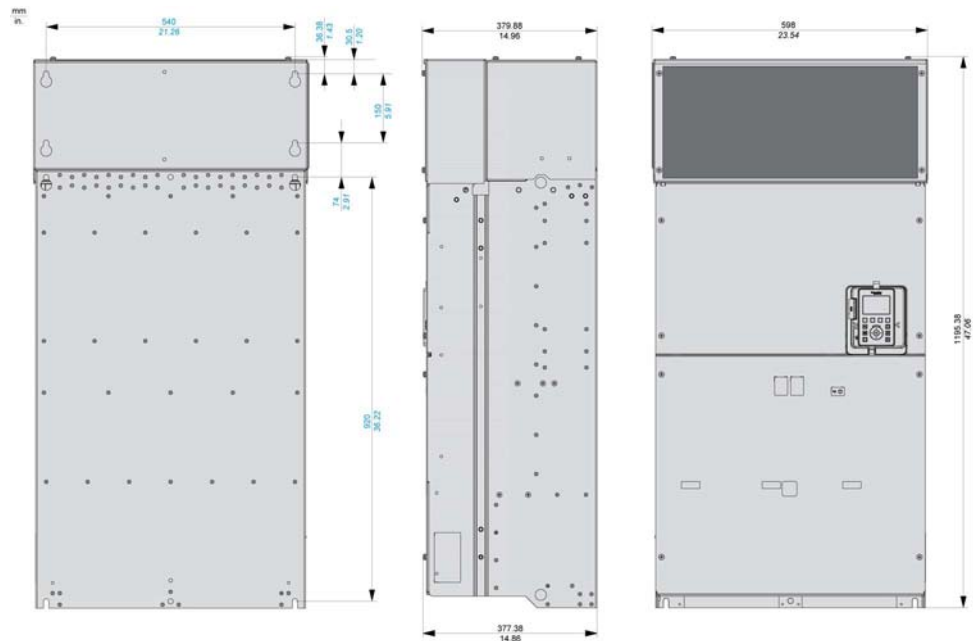

Weights

Catalog Number	Weight in kg (lb)
ATV930C25N4C, ATV930C31N4C	203 (448)

Frame Size A Without Load Switch

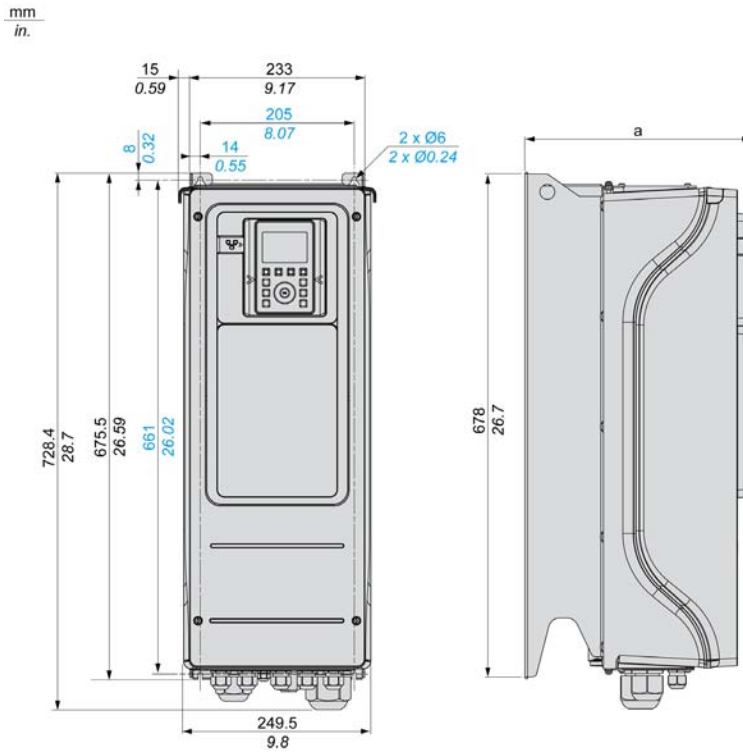

ATV950U07N4, U15N4, U22N4, U30N4, U40N4, U55N4: a = 272 mm (10.7 in.)

ATV950U75N4, D11N4, D15N4, D18N4, D22N4: a = 299 mm (11.8 in.)

Frame Size A With Load Switch

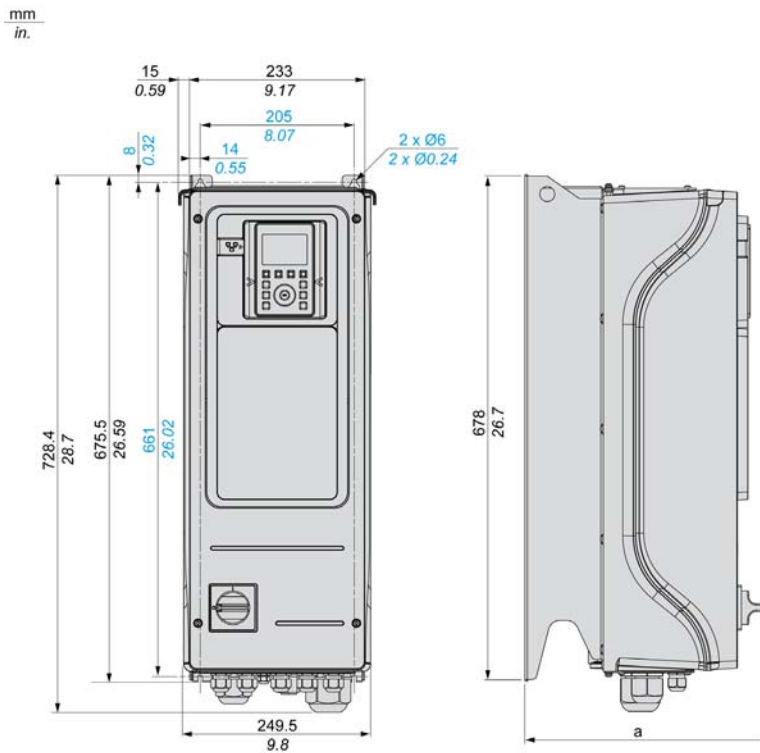

ATV950U07N4E, U15N4E, U22N4E, U30N4E, U40N4E, U55N4E: a = 300 mm (11.8 in.)

ATV950U75N4E, D11N4E, D15N4E, D18N4E, D22N4E: a = 330 mm (13 in.)

Weights

Catalog Number	Weight in kg (lb)
ATV950U07N4•...ATV950U22N4•	10.5 (23.1)
ATV950U30N4•, ATV950U40N4•	10.6 (23.4)
ATV950U55N4•	10.7 (23.6)
ATV950U75N4•, ATV950D11N4•	13.7 (30.2)
ATV950D15N4•	19.6 (43.2)
ATV950D18N4•, ATV950D22N4•	20.6 (45.4)

Frame Size B Without Load Switch

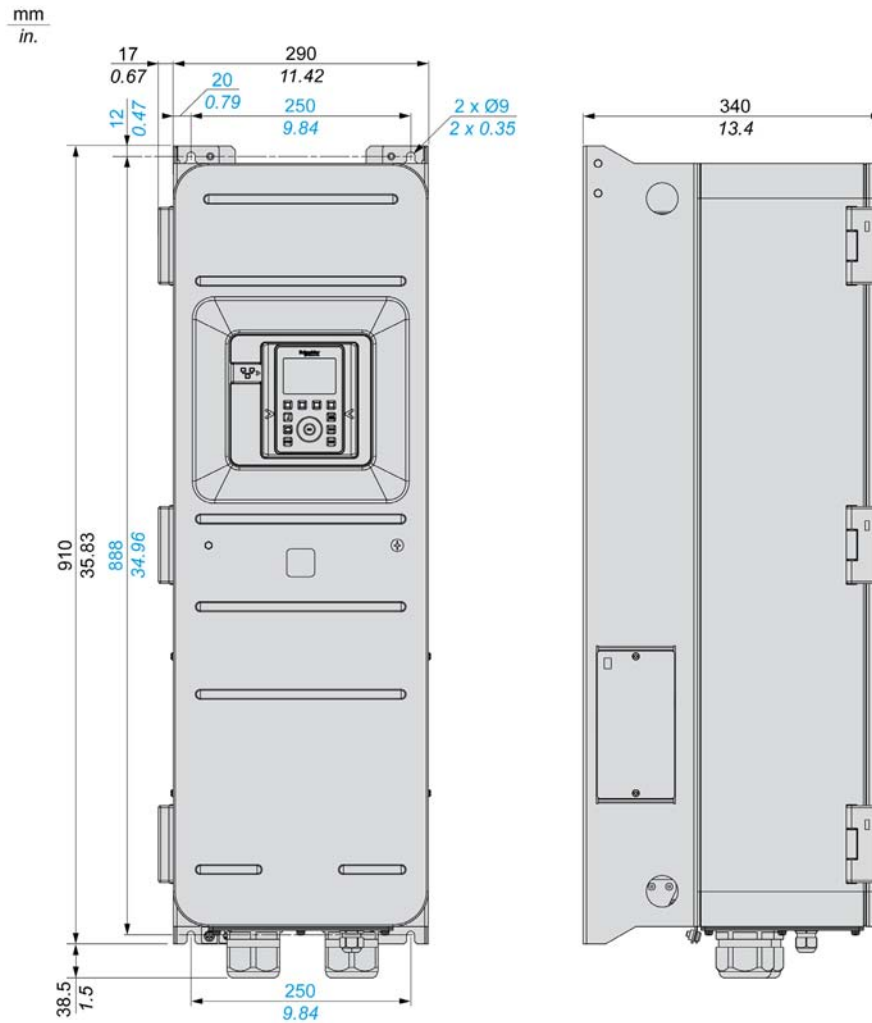

Frame Size B With Load Switch

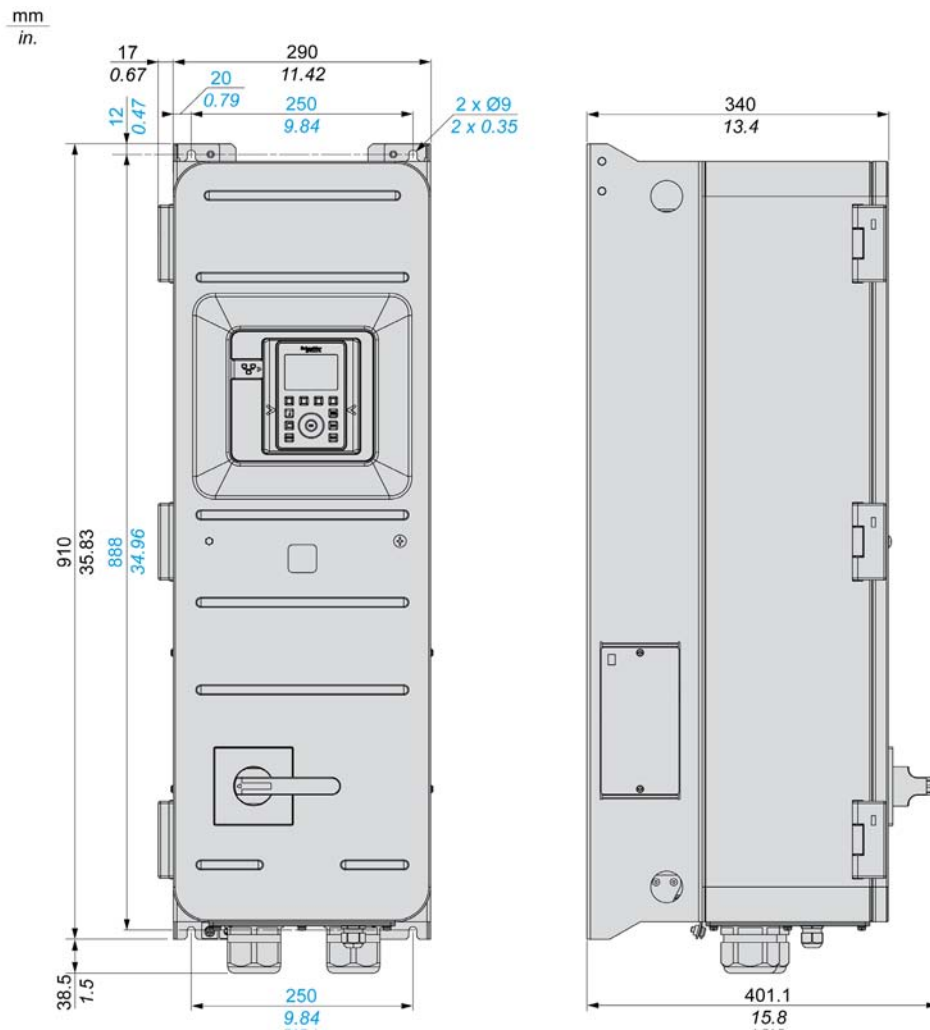

Weights

Catalog Number	Weight in kg (lb)
ATV950D30N4...ATV950D45N4	50 (110.2)
ATV950D30N4E...ATV950D45N4E	52 (114.6)

Frame Size C Without Load Switch

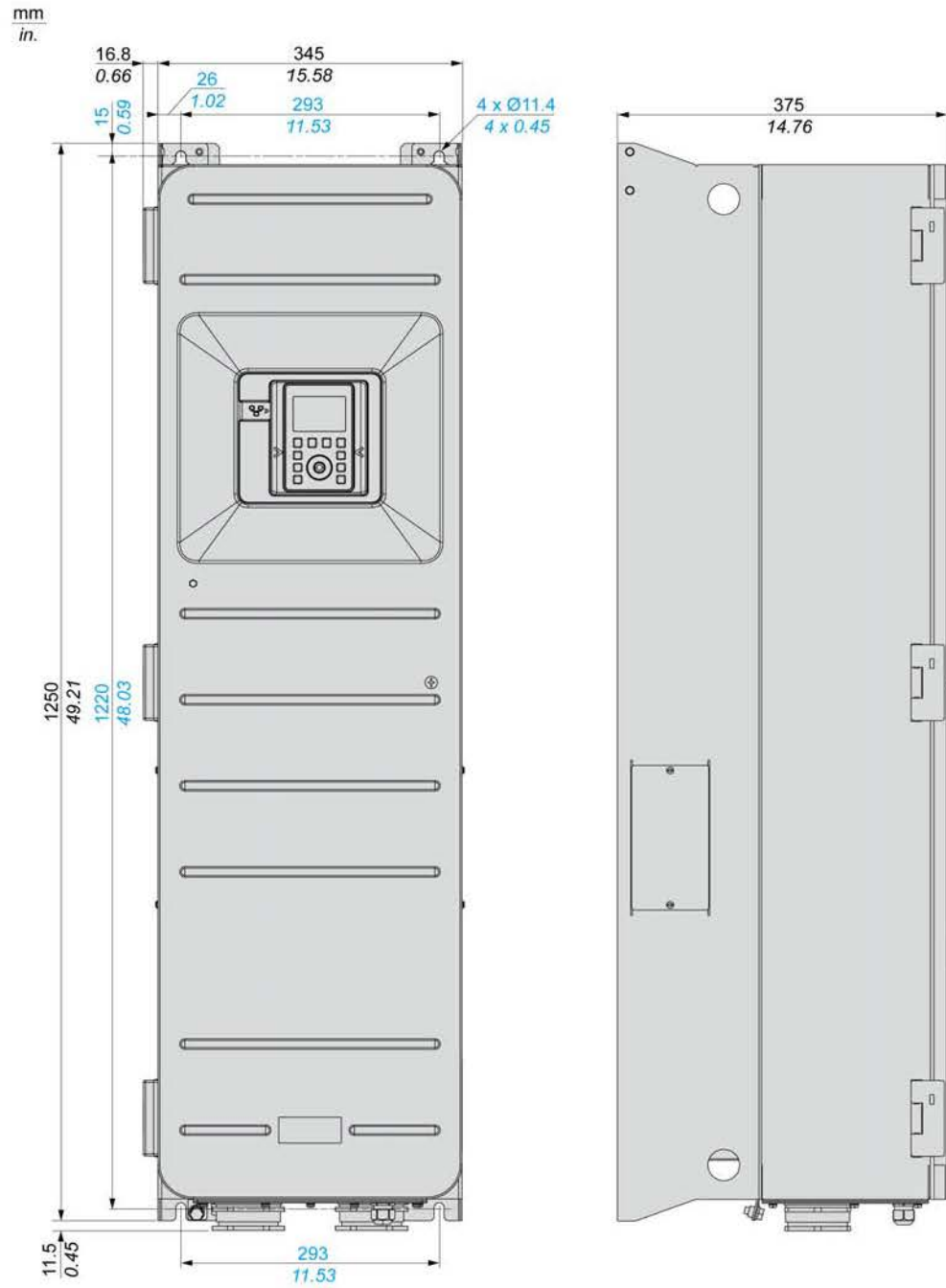

Frame size C With Load Switch

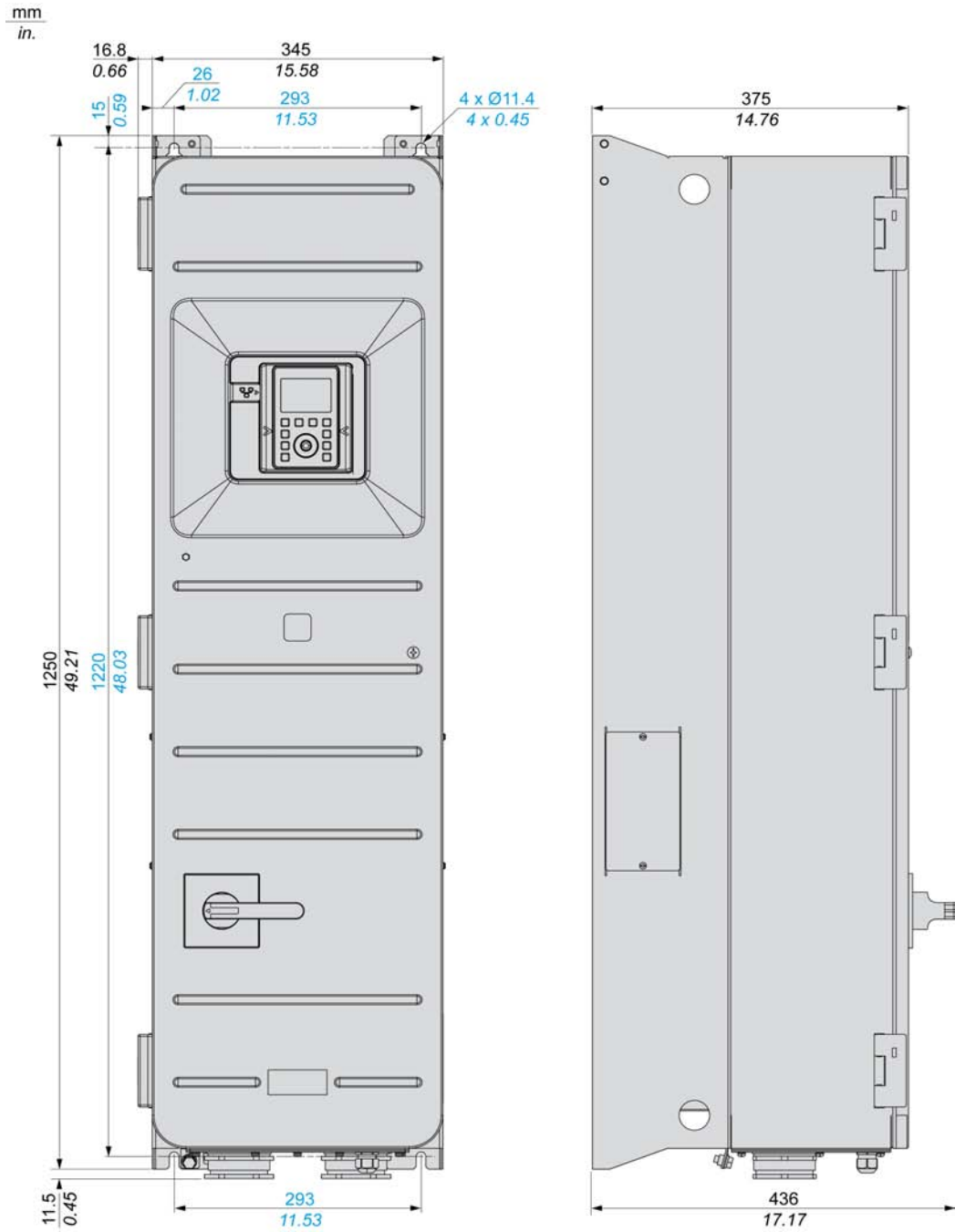

Weights

Catalog Number	Weight in kg (lb)
ATV950D55N4...ATV950D75N4	87.8 (193.6)
ATV950D55N4E...ATV950D75N4E	90.1 (198.6)
ATV950D90N4	88.5 (195.1)
ATV950D90N4E	90.8 (200.2)

Floor Standing - Frame Size FS1 and FSA

IP 21 Drives - Side and Front View

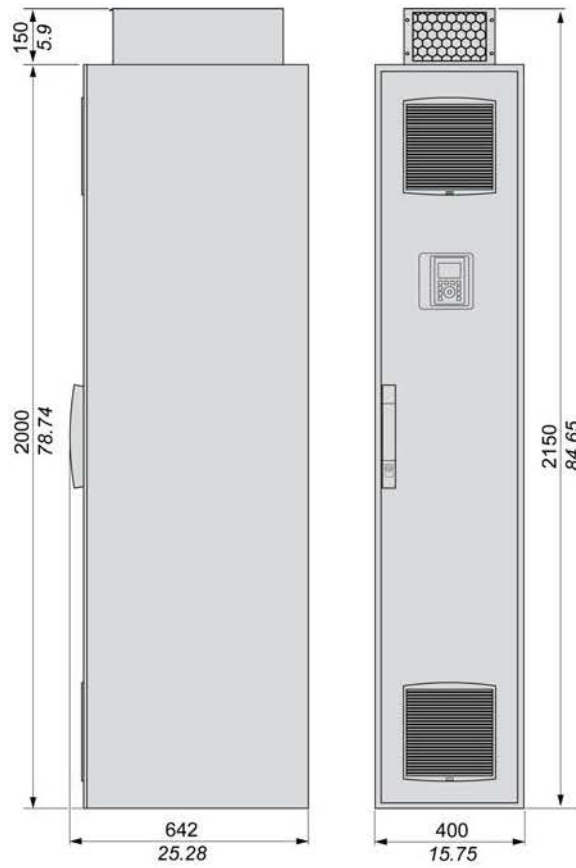

IP 54 Drives - Side and Front View

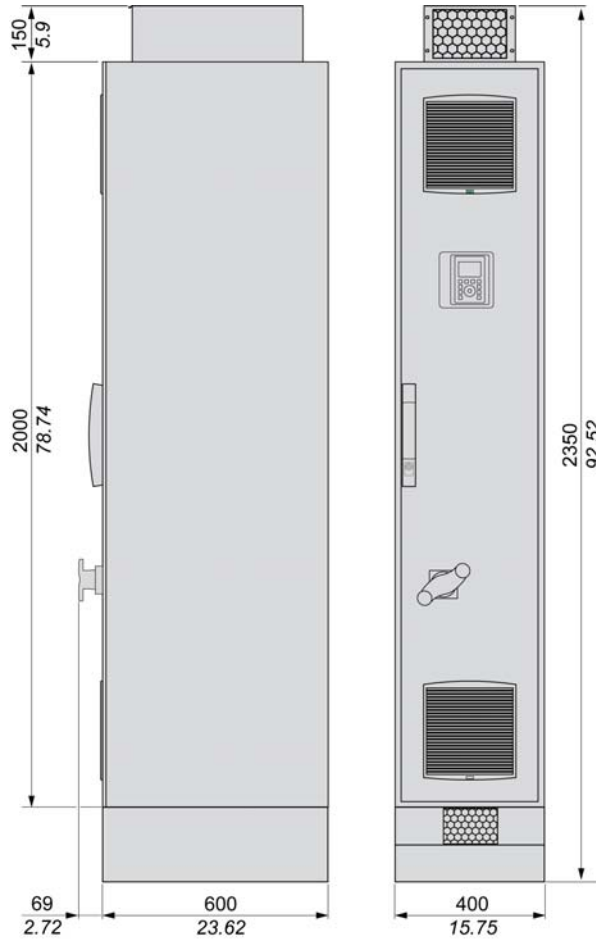

Weights

Catalog Number	Weight in kg (lb)
ATV930C11N4F...ATV930C16N4F	300 (661.4)
ATV950C11N4F...ATV950C16N4F	300 (661.4)

Floor Standing - Frame Size FS2 and FSB

IP 21 Drives - Side and Front View

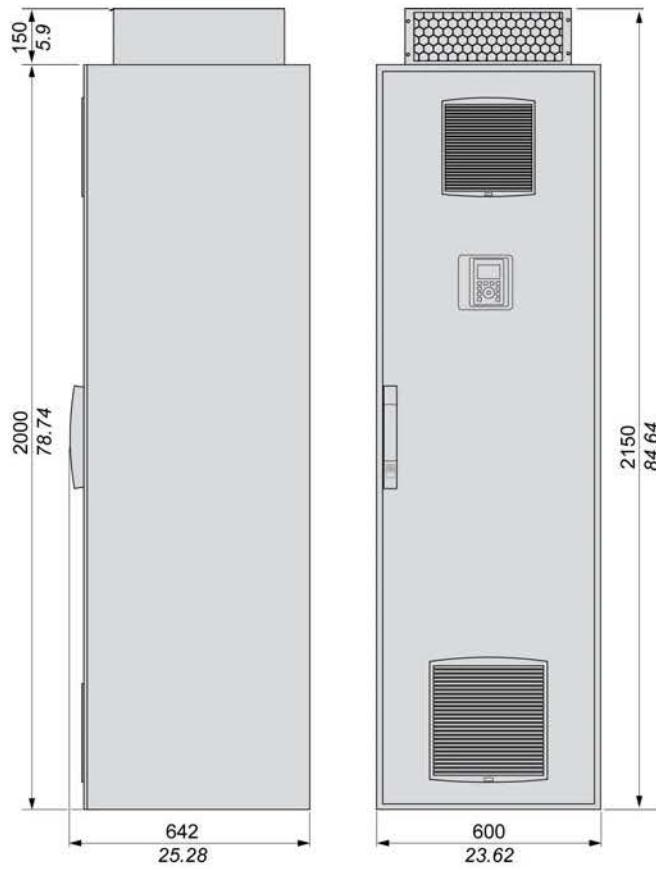

IP 54 Drives - Side and Front View

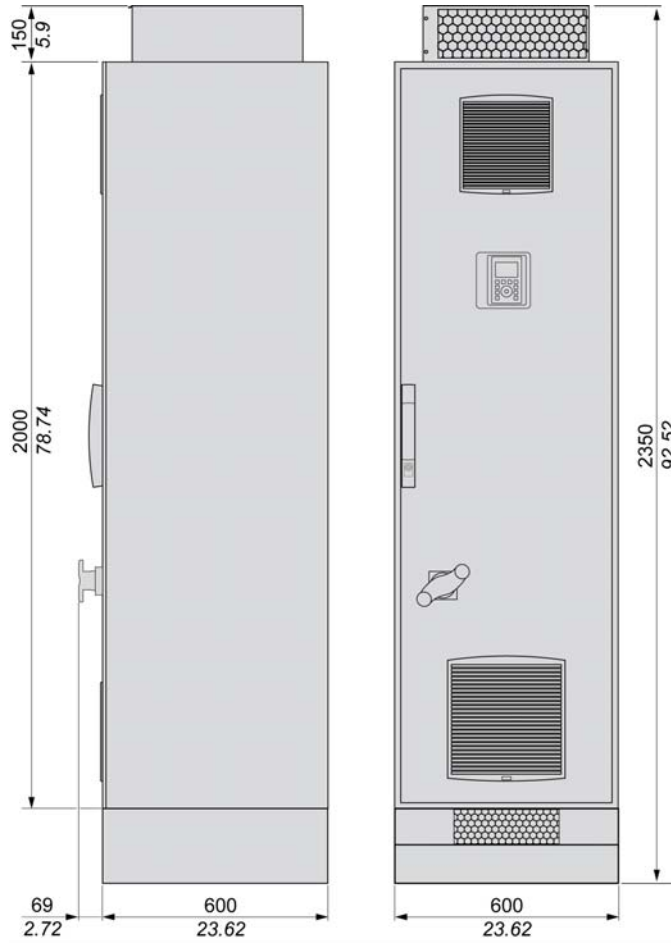

Weights

Catalog Number	Weight in kg (lb)
ATV930C20N4F...ATV930C31N4F	400 (882)
ATV950C20N4F...ATV950C31N4F	400 (882)

Section 2.3

Electrical Data

What Is in This Section?

This section contains the following topics:

Topic	Page
Drive Ratings In Normal Duty	54
Drive Ratings In Heavy Duty	58

Drive Ratings In Normal Duty

Normal Duty

Normal duty values are given for applications requiring a slight overload (up to 120 %).

NOTE: Refer to the Altivar Process 900 Getting Started Annex (SCCR) document [NHA61584](#) for fuse and circuit-breaker ratings for wall mounting drives.

IP21 / UL Type 1 Products 3-Phase Power Part Supply 200...240 Vac 50/60 Hz

Power and Current Ratings

Catalog Number and Frame Size (S•)		Nominal Power (1)		Power Part Supply				Drive (output)	
				Max. Input Current		Apparent Power	Max. Inrush Current (2)	Nominal Current (1)	Max. Transient current (1) (3)
				At 200 Vac	At 240 Vac				
kW	HP	A	A	kVA	A	A	A		
ATV930U07M3	S1	0.75	1	3	2.6	1.1	4.3	4.6	5.5
ATV930U15M3	S1	1.5	2	5.9	5	2.1	4.3	8	9.6
ATV930U22M3	S1	2.2	3	8.4	7.2	3.0	4.3	11.2	13.4
ATV930U30M3	S1	3	-	11.5	9.9	4.1	17.5	13.7	16.4
ATV930U40M3	S1	4	5	15.1	12.9	5.4	17.6	18.7	22.4
ATV930U55M3	S2	5.5	7 1/2	20.2	17.1	7.1	30.9	25.4	30.5
ATV930U75M3	S3	7.5	10	27.1	22.6	9.4	39.3	32.7	39.2
ATV930D11M3	S3	11	15	39.3	32.9	13.7	39.3	46.8	56.2
ATV930D15M3	S4	15	20	52.6	45.5	18.9	64.6	63.4	76.1
ATV930D18M3	S4	18.5	25	66.7	54.5	22.7	71.3	78.4	94.1
ATV930D22M3	S4	22	30	76	64.3	26.7	70.9	92.6	111.1
ATV930D30M3•	S5	30	40	104.7	88.6	36.8	133.3	123	147.6
ATV930D37M3•	S5	37	50	128	107.8	44.8	133.3	149	178.8
ATV930D45M3•	S5	45	60	155.1	130.4	54.2	175	176	211.2
ATV930D55M3C	S6	55	75	189	161	61.1	168.2	211	253.2
ATV930D75M3C	S6	75	100	256	215	83.7	168.2	282	338.4

(1) The switching frequency is adjustable:

- From 2...12 kHz for drive frame sizes 1 to 4, rated value: 4 kHz
- From 2...8 kHz for drive frame sizes 5 and 6, rated value: 2.5 kHz

For operation at switching frequencies higher than the rated value. Derating must be applied to the drive (output) current (*see page 72*). In this case, switching frequency can be reduced if an excessive temperature rise occurs.

(2) Peak current when power is switched on, for the maximum supply mains voltage.

(3) The drive is designed to run up to 60 s at 120% of nominal current.

IP21 / UL Type 1 Products 3-Phase Power Part Supply 380...480 Vac 50/60 Hz

Power and Current Ratings

Catalog Number and Frame Size (S*)		Nominal Power (1)		Power Part Supply				Drive (output)	
				Max. Input Current		Apparent Power	Max. Inrush Current (2)	Nominal Current (1)	Max. Transient current (1) (3)
				At 380 Vac	At 480 Vac				
kW	HP	A	A	kVA	A	A	A		
ATV930U07N4	S1	0.75	1	1.5	1.3	1.1	8	2.2	2.6
ATV930U15N4	S1	1.5	2	3	2.6	2.2	8.3	4	4.8
ATV930U22N4	S1	2.2	3	4.3	3.8	3.2	8.4	5.6	6.7
ATV930U30N4	S1	3	-	5.8	5.1	4.2	31.5	7.2	8.6
ATV930U40N4	S1	4	5	7.6	6.7	5.6	32.2	9.3	11.2
ATV930U55N4	S1	5.5	7 1/2	10.4	9.1	7.6	33.2	12.7	15.2
ATV930U75N4	S2	7.5	10	13.8	11.9	9.9	39.9	16.5	19.8
ATV930D11N4	S2	11	15	19.8	17	14.1	40.4	23.5	28.2
ATV930D15N4	S3	15	20	27	23.3	19.4	74.5	31.7	38.0
ATV930D18N4	S3	18.5	25	33.4	28.9	24	75.5	39.2	47.0
ATV930D22N4	S3	22	30	39.6	34.4	28.6	76	46.3	55.6
ATV930D30N4	S4	30	40	53.3	45.9	38.2	83	61.5	73.8
ATV930D37N4	S4	37	50	66.2	57.3	47.6	92	74.5	89.4
ATV930D45N4	S4	45	60	79.8	69.1	57.4	110	88	105.6
ATV930D55N4*	S5	55	75	97.2	84.2	70	176	106	127.2
ATV930D75N4*	S5	75	100	131.3	112.7	93.7	187	145	174.0
ATV930D90N4*	S5	90	125	156.2	135.8	112.9	236	173	207.6
ATV930C11N4C	S6	110	150	201	165	121.8	325	211	253.0
ATV930C13N4C	S6	132	200	237	213	161.4	325	250	300.0
ATV930C16N4C	S6	160	250	284	262	201.3	325	302	362.0
ATV930C22N4	S7a	220	350	397	324	247	426	427	470
ATV930C22N4C	S7a	220	350	397	324	247	426	427	470
ATV930C25N4C	S7b	250	400	451	366	279	450	481	529
ATV930C31N4C	S7b	315	500	569	461	351	615	616	678

(1) The switching frequency is adjustable:

- From 2...16 kHz for drive frame sizes 1 to 4, rated value: 4 kHz
- From 2...8 kHz for drive frame sizes 5 and 6, rated value: 2.5 kHz

For operation at switching frequencies higher than the rated value. Derating must be applied to the drive (output) current (*see page 72*). In this case, switching frequency can be reduced if an excessive temperature rise occurs.

(2) Peak current when power is switched on, for the maximum supply mains voltage.

(3) The drive is designed to run up to 60 s at 120% of nominal current.

IP55 Products 3-Phase Power Part Supply 380...480 Vac 50/60 Hz

Power and Current Ratings

Catalog Number and Frame Size (S*)		Nominal Power (1)		Power Part Supply				Drive (output)	
				Max. Input Current		Apparent Power	Max. Inrush Current (2)	Nominal Current (1)	Max. Transient current (1) (3)
				At 380 Vac	At 480 Vac				
kW	HP	A	A	kVA	A	A	A		
ATV950U07N4*	SA	0.75	1	1.5	1.3	1.1	8	2.2	2.6
ATV950U15N4*	SA	1.5	2	3	2.6	2.2	8.3	4	4.8
ATV950U22N4*	SA	2.2	3	4.3	3.8	3.2	8.4	5.6	6.7
ATV950U30N4*	SA	3	-	5.8	5.1	4.2	31.5	7.2	8.6
ATV950U40N4*	SA	4	5	7.6	6.7	5.6	32.2	9.3	11.2
ATV950U55N4*	SA	5.5	7 1/2	10.4	9.1	7.6	33.2	12.7	15.2
ATV950U75N4*	SA	7.5	10	13.8	11.9	9.9	39.9	16.5	19.8
ATV950D11N4*	SA	11	15	19.8	17	14.1	40.4	23.5	28.2
ATV950D15N4*	SA	15	20	27	23.3	19.4	74.5	31.7	38.0
ATV950D18N4*	SA	18.5	25	33.4	28.9	24	75.5	39.2	47.0
ATV950D22N4*	SA	22	30	39.6	34.4	28.6	76	46.3	55.6
ATV950D30N4*	SB	30	40	53.3	45.9	38.2	83	61.5	73.8
ATV950D37N4*	SB	37	50	66.2	57.3	47.6	92	74.5	89.4
ATV950D45N4*	SB	45	60	79.8	69.1	57.4	110	88	105.6
ATV950D55N4*	SC	55	75	97.2	84.2	70	176	106	127.2
ATV950D75N4*	SC	75	100	131.3	112.7	93.7	187	145	174
ATV950D90N4*	SC	90	125	156.2	135.8	112.9	236	173	207.6

(1) The switching frequency is adjustable:

- From 2...12 kHz for drive frame sizes A and B, rated value: 4 kHz
- From 2...8 kHz for drive frame size C, rated value: 2.5 kHz

For operation at switching frequencies higher than the rated value. Derating must be applied to the drive (output) current (*see page 72*). In this case, switching frequency can be reduced if an excessive temperature rise occurs.

(2) Peak current when power is switched on, for the maximum supply mains voltage.

(3) The drive is designed to run up to 60 s at 120% of nominal current.

IP21 Products 3-Phase Power Part Supply 380...440 Vac 50/60 Hz - Floor standing

Power and Current Ratings

Catalog Number	Nominal Power (1)	Power Part Supply				Drive (output)	
		Max. Input Current		Apparent Power	Max. Inrush Current (2)	Nominal Current (1)	Max. Transient current (1) (3)
		At 380 Vac	At 440 Vac				
kW	A	A	kVA	A	A	A	
ATV930C11N4F	110	207	179	136	187	211	253
ATV930C13N4F	132	244	210	160	187	250	300
ATV930C16N4F	160	291	251	191	187	302	362
ATV930C20N4F	200	369	319	243	345	370	444
ATV930C25N4F	250	453	391	298	345	477	572
ATV930C31N4F	315	566	488	372	345	590	708

(1) The switching frequency is adjustable from 2...8 kHz with a rated value of 2.5 kHz

For operation at switching frequencies higher than the rated value. Derating must be applied to the drive (output) current (*see page 72*). In this case, switching frequency can be reduced if an excessive temperature rise occurs.

(2) Peak current when power is switched on, for the maximum supply mains voltage.

(3) The drive is designed to run up to 60 s at 120% of nominal current.

IP54 Products 3-Phase Power Part Supply 380...440 Vac 50/60 Hz - Floor standing

Power and Current Ratings

Catalog Number	Nominal Power (1)	Power Part Supply				Drive (output)	
		Max. Input Current		Apparent Power	Max. Inrush Current (2)	Nominal Current (1)	Max. Transient current (1) (3)
		At 380 Vac	At 440 Vac				
	kW	A	A	kVA	A	A	A
ATV950C11N4F	110	207	176	136	187	211	253
ATV950C13N4F	132	244	210	160	187	250	300
ATV950C16N4F	160	291	251	191	187	302	362
ATV950C20N4F	200	369	319	243	345	370	444
ATV950C25N4F	250	453	391	298	345	477	572
ATV950C31N4F	315	566	488	372	345	590	708

(1) The switching frequency is adjustable from 2...8 kHz with a rated value of 2.5 kHz
For operation at switching frequencies higher than the rated value. Derating must be applied to the drive (output) current (*see page 72*). In this case, switching frequency can be reduced if an excessive temperature rise occurs.

(2) Peak current when power is switched on, for the maximum supply mains voltage.

(3) The drive is designed to run up to 60 s at 120% of nominal current.

Floor Standing Drives - Fuse and Circuit-breaker Ratings

Catalog Number	Nominal Power	Upstream Cables		Internal Circuits
		gG Class Pre-fuse	Circuit-breaker I_{therm}	aR fuse
		A	A	A
ATV9*0C11N4F	110	250	230	250
ATV9*0C13N4F	132	300	280	315
ATV9*0C16N4F	160	315	315	350
ATV9*0C20N4F	200	400	400	2 x 250
ATV9*0C25N4F	250	500	500	2 x 315
ATV9*0C31N4F	315	630	630	2 x 400

Drive Ratings In Heavy Duty

Heavy Duty

Heavy-duty values are given for applications requiring a significant overload (up to 150 %).

NOTE: Refer to the Altivar Process 900 Getting Started Annex (SCCR) document [NHA61584](#) for fuse and circuit-breaker ratings for wall mounting drives.

IP21 / UL Type 1 Products 3-Phase Power Part Supply 200...240 Vac 50/60 Hz

Power And Current Ratings

Catalog Number and Frame Size (S•)		Nominal Power (1)		Power Part Supply				Drive (output)	
				Max. Input Current		Apparent Power	Max. Inrush Current (2)	Nominal Current (1)	Max. Transient current (1) (3)
				At 200 Vac	At 240 Vac				
kW	HP	A	A	kVA	A	A	A		
ATV930U07M3	S1	0.4	1/2	1.7	1.5	0.6	4.3	3.3	5
ATV930U15M3	S1	0.8	1	3.3	3	1.2	4.3	4.6	6.9
ATV930U22M3	S1	1.5	2	6	5.3	2.2	4.3	8	12
ATV930U30M3	S1	2.2	3	8.7	7.6	3.2	17.5	11.2	16.8
ATV930U40M3	S1	3	–	11.7	10.2	4.2	17.6	13.7	20.6
ATV930U55M3	S2	4	5	15.1	13	5.4	30.9	18.7	28.1
ATV930U75M3	S3	5.5	7 1/2	20.1	16.9	7	39.3	25.4	38.1
ATV930D11M3	S3	7.5	10	27.2	23.1	9.6	39.3	32.7	49.1
ATV930D15M3	S4	11	15	40.1	34.3	14.3	64.6	46.8	70.2
ATV930D18M3	S4	15	20	53.1	44.9	18.7	71.3	63.4	95.1
ATV930D22M3	S4	18.5	25	64.8	54.5	22.7	70.9	78.4	117.6
ATV930D30M3•	S5	22	30	78.3	67.1	27.9	133.3	92.6	138.9
ATV930D37M3•	S5	30	40	104.7	88.6	36.8	133.3	123	184.5
ATV930D45M3•	S5	37	50	128.5	108.5	45.1	175	149	223.5
ATV930D55M3C	S6	45	60	156	134	50	168.2	176	264
ATV930D75M3C	S6	55	75	189	161	61.1	168.2	211	316.5

(1) The switching frequency is adjustable:

- From 2...12 kHz for drive frame sizes 1 to 4, rated value: 4 kHz
- From 2...8 kHz for drive frame sizes 5 and 6, rated value: 2.5 kHz

For operation at switching frequencies higher than the rated value. Derating must be applied to the drive (output) current (*see page 72*). In this case, switching frequency can be reduced if an excessive temperature rise occurs.

(2) Peak current when power is switched on, for the maximum supply mains voltage.

(3) The drive is designed to run up to 60 s at 150% of nominal current.

IP21 / UL Type 1 Products 3-Phase Power Part Supply 380...480 Vac 50/60 Hz

Power And Current Ratings

Catalog Number and Frame Size (S*)		Nominal Power (1)		Power Part Supply				Drive (output)	
				Max. Input Current		Apparent Power	Max. Inrush Current (2)	Nominal Current (1)	Max. Transient current (1) (3)
				At 380 Vac	At 480 Vac				
kW	HP	A	A	kVA	A	A	A		
ATV930U07N4	S1	0.37	1/2	0.9	0.8	0.7	8	1.5	2.3
ATV930U15N4	S1	0.75	1	1.7	1.5	1.2	8.3	2.2	3.3
ATV930U22N4	S1	1.5	2	3.1	2.9	2.4	8.4	4	6
ATV930U30N4	S1	2.2	3	4.5	4.0	3.3	31.5	5.6	8.4
ATV930U40N4	S1	3	-	6.0	5.4	4.5	32.2	7.2	10.8
ATV930U55N4	S1	4	5	8	7.2	6.0	33.2	9.3	14
ATV930U75N4	S2	5.5	7 1/2	10.5	9.2	7.6	39.9	12.7	19.1
ATV930D11N4	S2	7.5	10	14.1	12.5	10.4	40.4	16.5	24.8
ATV930D15N4	S3	11	15	20.6	18.1	15	74.5	23.5	35.3
ATV930D18N4	S3	15	20	27.7	24.4	20.3	75.5	31.7	47.6
ATV930D22N4	S3	18.5	25	34.1	29.9	24.9	76	39.2	58.8
ATV930D30N4	S4	22	30	40.5	35.8	29.8	83	46.3	69.5
ATV930D37N4	S4	30	40	54.8	48.3	40.2	92	61.5	92.3
ATV930D45N4	S4	37	50	67.1	59	49.1	110	74.5	111.8
ATV930D55N4*	S5	45	60	81.4	71.8	59.7	176	88	132
ATV930D75N4*	S5	55	75	98.9	86.9	72.2	187	106	159
ATV930D90N4*	S5	75	100	134.3	118.1	98.2	236	145	217.5
ATV930C11N4C	S6	90	125	170	143	102.6	325	173	259.5
ATV930C13N4C	S6	110	150	201	165	121.8	325	211	317
ATV930C16N4C	S6	132	200	237	213	161.4	325	250	375
ATV930C22N4	S7a	160	250	296	246	187	426	302	453
ATV930C22N4C	S7a	160	250	296	246	187	426	302	453
ATV930C25N4C	S7b	200	350	365	301	229	450	387	581
ATV930C31N4C	S7b	250	400	457	375	286	615	481	722

(1) The switching frequency is adjustable:

- From 2...12 kHz for drive frame sizes 1 to 4, rated value: 4 kHz
- From 2...8 kHz for drive frame sizes 5 and 6, rated value: 2.5 kHz

For operation at switching frequencies higher than the rated value. Derating must be applied to the drive (output) current (*see page 72*). In this case, switching frequency can be reduced if an excessive temperature rise occurs.

(2) Peak current when power is switched on, for the maximum supply mains voltage.

(3) The drive is designed to run up to 60 s at 150% of nominal current.

IP21 Products 3-Phase Power Part Supply 380...440 Vac 50/60 Hz - Floor standing

Power And Current Ratings

Catalog Number	Nominal Power (1)	Power Part Supply				Drive (output)	
		Max. Input Current		Apparent Power	Max. Inrush Current (2)	Nominal Current (1)	Max. Transient current (1) (3)
		At 380 Vac	At 400 Vac				
kW	A	A	kVA	A	A	A	
ATV930C11N4F	90	174	151	115	187	173	260

(1) The switching frequency is adjustable from 2...8 kHz with a rated value of 2.5 kHz
For operation at switching frequencies higher than the rated value. Derating must be applied to the drive (output) current (*see page 72*). In this case, switching frequency can be reduced if an excessive temperature rise occurs.

(2) Peak current when power is switched on, for the maximum supply mains voltage.

(3) The drive is designed to run up to 60 s at 150% of nominal current.

Catalog Number	Nominal Power (1)		Power Part Supply				Drive (output)	
			Max. Input Current		Apparent Power	Max. Inrush Current (2)	Nominal Current (1)	Max. Transient current (1) (3)
			At 380 Vac	At 400 Vac				
	kW		A	A	kVA	A	A	A
ATV930C13N4F	110		207	179	136	187	211	317
ATV930C16N4F	132		244	210	160	187	250	375
ATV930C20N4F	160		302	262	200	345	302	453
ATV930C25N4F	200		369	319	243	345	370	555
ATV930C31N4F	250		453	391	298	345	477	716

(1) The switching frequency is adjustable from 2...8 kHz with a rated value of 2.5 kHz
For operation at switching frequencies higher than the rated value. Derating must be applied to the drive (output) current (*see page 72*). In this case, switching frequency can be reduced if an excessive temperature rise occurs.
(2) Peak current when power is switched on, for the maximum supply mains voltage.
(3) The drive is designed to run up to 60 s at 150% of nominal current.

IP55 Products 3-Phase Power Part Supply 380...480 Vac 50/60 Hz

Power And Current Ratings

Catalog Number and Frame Size (S*)		Nominal Power (1)		Power Part Supply				Drive (output)	
				Max. Input Current		Apparent Power	Max. Inrush Current (2)	Nominal current (1)	Max. transient current (1) (3)
		At 380 Vac	At 480 Vac						
		kW	HP	A	A	kVA	A	A	A
ATV950U07N4•	SA	0.37	1/2	0.9	0.8	0.7	8.0	1.5	2.3
ATV950U15N4•	SA	0.75	1	1.7	1.5	1.2	8.3	2.2	3.3
ATV950U22N4•	SA	1.5	2	3.1	2.9	2.4	8.4	4	6
ATV950U30N4•	SA	2.2	3	4.5	4.0	3.3	31.5	5.6	8.4
ATV950U40N4•	SA	3	-	6	5.4	4.5	32.2	7.2	10.8
ATV950U55N4•	SA	4	5	8	7.2	6.0	33.2	9.3	14
ATV950U75N4•	SA	5.5	7 1/2	10.5	9.2	7.6	39.9	12.7	19.1
ATV950D11N4•	SA	7.5	10	14.1	12.5	10.4	40.4	16.5	24.8
ATV950D15N4•	SA	11	15	20.6	18.1	15	74.5	23.5	35.3
ATV950D18N4•	SA	15	20	27.7	24.4	20.3	75.5	31.7	47.6
ATV950D22N4•	SA	18.5	25	34.1	29.9	24.9	76	39.2	58.8
ATV950D30N4•	SB	22	30	40.5	35.8	29.8	83	46.3	69.5
ATV950D37N4•	SB	30	40	54.8	48.3	40.2	92	61.5	92.3
ATV950D45N4•	SB	37	50	67.1	59	49.1	109.7	74.5	111.8
ATV950D55N4•	SC	45	60	81.4	71.8	59.7	176	88	132
ATV950D75N4•	SC	55	75	98.9	86.9	72.2	187	106	159
ATV950D90N4•	SC	75	100	134.3	118.1	98.2	236	145	217.5

(1) The switching frequency is adjustable:
 ○ From 2...12 kHz for drive frame sizes A and B, rated value: 4 kHz
 ○ From 2...8 kHz for drive frame size C, rated value: 2.5 kHz
 For operation at switching frequencies higher than the rated value. Derating must be applied to the drive (output) current (*see page 72*). In this case, switching frequency can be reduced if an excessive temperature rise occurs.
 (2) Peak current when power is switched on, for the maximum supply mains voltage.
 (3) The drive is designed to run up to 60 s at 150% of nominal current.

IP54 Products 3-Phase Power Part Supply 380...440 Vac 50/60 Hz - Floor standing

Power And Current Ratings

Catalog Number	Nominal Power (1) kW	Power Part Supply				Drive (output)	
		Max. Input Current		Apparent Power	Max. Inrush Current (2)	Nominal Current (1)	Max. Transient current (1) (3)
		At 380 Vac	At 400 Vac				
A	A	kVA	A	A	A	A	
ATV950C11N4F	90	174	151	115	187	173	260
ATV950C13N4F	110	207	179	136	187	211	317
ATV950C16N4F	132	244	210	160	187	250	375
ATV950C20N4F	160	302	262	200	345	302	453
ATV950C25N4F	200	369	319	243	345	370	555
ATV950C31N4F	250	453	391	298	345	477	716

(1) The switching frequency is adjustable from 2...8 kHz with a rated value of 2.5 kHz
For operation at switching frequencies higher than the rated value. Derating must be applied to the drive (output) current (*see page 72*). In this case, switching frequency can be reduced if an excessive temperature rise occurs.

(2) Peak current when power is switched on, for the maximum supply mains voltage.

(3) The drive is designed to run up to 60 s at 150% of nominal current.

Floor Standing Drives - Fuse and Circuit-breaker Ratings

Catalog Number	Nominal Power	Upstream Cables		Internal Circuits
		gG Class Pre-fuse	Circuit-breaker I_{therm}	aR fuse
	kW	A	A	A
ATV9*0C11N4F	90	250	200	250
ATV9*0C13N4F	110	300	240	315
ATV9*0C16N4F	132	300	280	350
ATV9*0C20N4F	160	355	330	2 x 250
ATV9*0C25N4F	200	400	400	2 x 315
ATV9*0C31N4F	250	500	500	2 x 400

Chapter 3

Drive Mounting

What Is in This Chapter?

This chapter contains the following topics:

Topic	Page
Mounting Conditions	64
Derating Curves	72
Mounting Procedures	80

Mounting Conditions

Before You Begin

Conductive foreign objects, dust or liquids or damaged parts may cause parasitic voltage.

 DANGER
ELECTRIC SHOCK CAUSED BY FOREIGN OBJECTS OR DAMAGE <ul style="list-style-type: none">• Do not use damaged products.• Keep foreign objects such as chips, screws or wire clippings from getting into the product.• Verify correct seat of seals and cable entries in order to avoid deposits and humidity. Failure to follow these instructions will result in death or serious injury.

The temperature of the products described in this manual may exceed 80 °C (176 °F) during operation.

 WARNING
HOT SURFACES <ul style="list-style-type: none">• Ensure that any contact with hot surfaces is avoided.• Do not allow flammable or heat-sensitive parts in the immediate vicinity of hot surfaces.• Verify that the product has sufficiently cooled down before handling it.• Verify that the heat dissipation is sufficient by performing a test run under maximum load conditions. Failure to follow these instructions can result in death, serious injury, or equipment damage.

Attaching A Label With Safety Instructions

A label kit is provided with the drive.

Step	Action
1	Observe the safety regulations in the target country
2	Select the label suitable for the target country
3	Attach the label to the front of the device so that it is clearly visible. Below is the English version. The label can vary depending on the frame size of the product. 

Mounting Types

This table shows the possible mounting types and the resulting IP degree of protection.

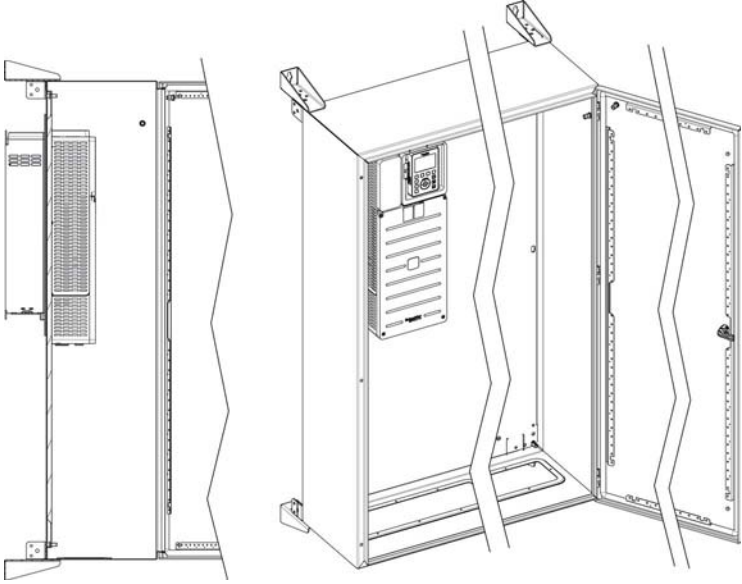
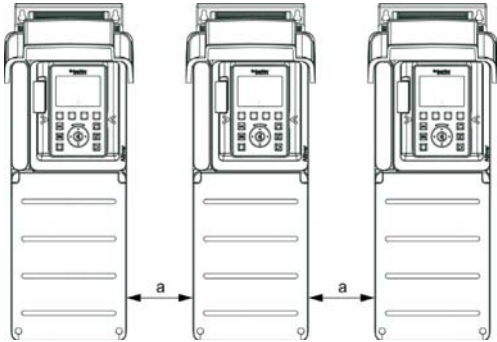
Mounting		Figure
Type	Description	
–	Enclosed with flush-mounting kit	<p>This mounting is used to reduce the power dissipated in the enclosure by locating the power section outside the enclosure.</p>  <p>This mounting type requires the dedicated mounting kit available on www.schneider-electric.com</p> <p>NOTE: Use ProClima software available on www.schneider-electric.com to support you to integrate Altivar Process in an enclosure.</p>
A	Individual IP21	 <p>Frame sizes 1, 2 and 3: $a \approx 100 \text{ mm}$ (3.9 in.) Frame sizes 4, 5 and 6: $a \approx 110 \text{ mm}$ (4.33 in.) Frame size 7: no restriction of clearance</p>

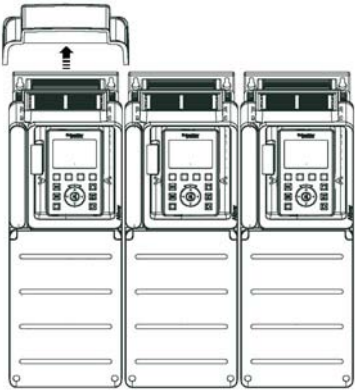
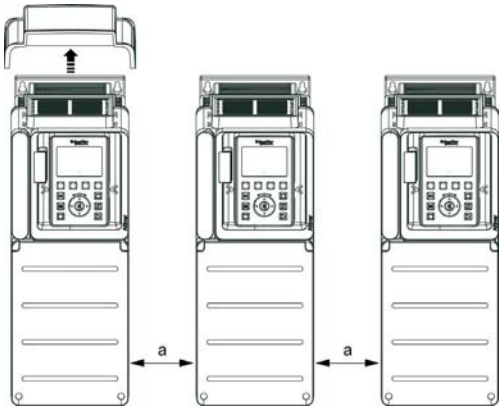
Mounting		Figure
Type	Description	
B	Side by side IP20	 <p>Frame sizes 1, 2, 3 and 7: possible Frame sizes 4 and 5: possible, 2 drives only Frame size 6: only at ambient temperature lower than 40 °C (104 °F)</p>
C	Individual IP20	 <p>Frame sizes 1, 2, 3 and 7: no restriction of clearance Frame sizes 4, 5 and 6: $a \geq 110 \text{ mm (4.33 in.)}$</p>

Clearances and Mounting Position - Wall Mounting

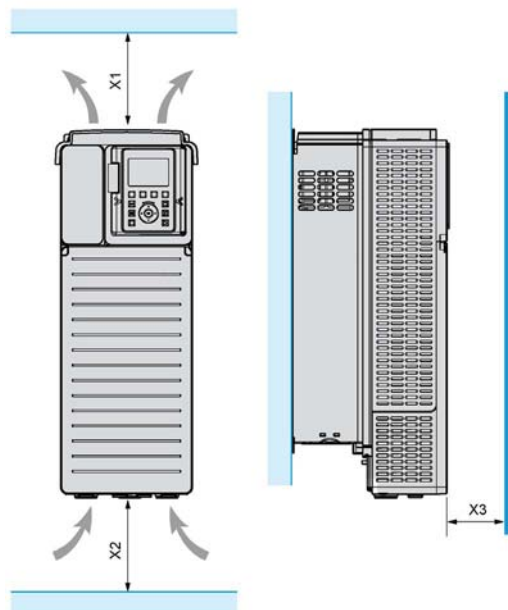

Minimum clearance regarding the drive frame size

Frame Size	X1	X2	X3
1...5	≥ 100 mm (3.94 in.)	≥ 100 mm (3.94 in.)	≥ 10 mm (0.39 in.)
SA...SC	≥ 100 mm (3.94 in.)	≥ 100 mm (3.94 in.)	≥ 10 mm (0.39 in.)
6	≥ 250 mm (10 in.)	≥ 250 mm (10 in.)	≥ 100 mm (3.94 in.)
7	≥ 200 mm (7.87 in.)	≥ 150 mm (5.90 in.)	≥ 10 mm (0.39 in.)

X1: free space in top of the drive

X2: free space in bottom of the drive

X3: free space in front of the drive

Clearances and Mounting Position - Floor Standing

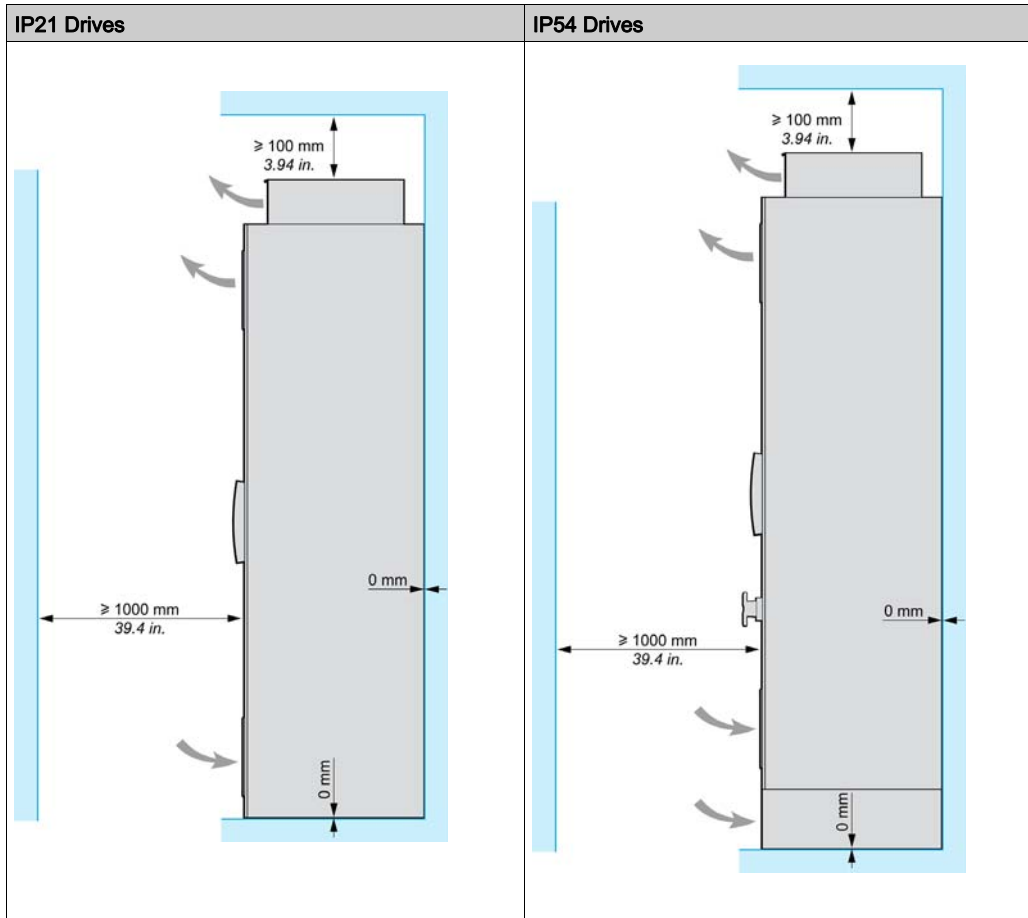

Frame Size 7 Drive - IP23 Mounting in Enclosure

Install the drive as described below:

Step	Action	Drawing and Comments
1	Install the drive on an enclosure baseplate	
2	Install the DC choke in accordance with the mounting instructions (see page 83).	
3	Install the UL Type 1, IP21 kit (4) for attaching the power cables, in accordance with the mounting instructions supplied with the kit	
4	Extend the IP54 duct (1) between the upper outlet of the DC choke and the top of the enclosure (2). Fixing points are provided for this purpose on the top of the DC choke.	
5	Add a plate (3) approximately 150 mm (6 in.) from the top of the enclosure over the air outlet opening to prevent foreign bodies falling into the drive cooling duct.	The air inlet can be via a grille on the bottom front panel of the enclosure door, in accordance with the required flow rates given in the above table.

NOTE:

- If the air in the power circuit is totally evacuated to the outside, very few power is dissipated inside the enclosure.
- Connect all the additional metal parts to ground using the strips.
- The design of the UL Type 1, IP21 kit ④ (to be ordered as an option) is based on the same principle as the DC choke, and has an IP54 duct to help guide the incoming air.

Frame Size 7 Drive - IP54 Mounting in Enclosure

Install the drive as described in the IP23 mounting section with the following additional points to obtain an IP54 enclosure:

Step	Action	Drawing and Comments
1	Do not make an air outlet hole for the control section. Do not make an air inlet hole in the enclosure door. In the power section, the air will enter through the bottom of the enclosure via a plinth added for this purpose.	
2	Install the IP21 UL Type 1 kit ①, if required in accordance with the mounting instructions supplied with the kit	
3	Add an enclosure baseplate ② designed to provide IP54 protection around the power cables.	
4	Add an air evacuation duct ③ between the baseplate and the duct of the UL type 1 conformity kit. The conformity kit enables an extension duct to be mounted. Drill a hole in the base of the enclosure to allow air to enter. Place seals around the duct that has been added to maintain IP54 protection.	
5	Add a 200 mm plinth ④ at the bottom of the enclosure with grilles to allow air to enter.	
6	Use the dissipated power table below to calculate the enclosure dimensions.	

NOTE:

- Connect all the additional metal parts to ground using the strips.

Power dissipated by the control section inside the enclosure

These levels of power dissipation are given for operation at nominal load and for the factory-set switching frequency.

Catalog Number	Dissipated Power in W (1)
ATV930C22N4	451
ATV930C22N4C	451
ATV930C25N4C	606
ATV930C31N4C	769
(1) Add 7W to this value for each option card added	

General Mounting Instructions

- Mount the device in a vertical position. This is required for cooling the device.
- Attach it on the mounting surface in compliance with standards, using 4 screws with captive washer according to the table given in Mounting Procedures (*see page 80*).
- The use of washers is required with all mounting screws.
- Tighten the fixation screws.
- Do not mount the device close to heat sources.
- Avoid environmental effects like high temperatures and high humidity as well as dust, dirt and conductive gases.
- Adhere to the minimum installation distances for required cooling.
- Do not mount the device on flammable materials.
- Install the Altivar Process floor standing drive on a solid, vibration-free ground.

Power Dissipated For Enclosed Drives and Required Air Flow - Wall Mounting

Catalog Number	Frame Size	Power Dissipated (1)			Minimum air flow rate required per hour	
		Forced Cooled Area	Natural Cooled Area	Total	(m ³)	(yd ³)
		(W)	(W)	(W)		
ATV930U07M3	1	28	27	55	38	50
ATV930U15M3	1	53	29	82	38	50
ATV930U22M3	1	74	32	105	38	50
ATV930U30M3	1	104	34	137	38	50
ATV930U40M3	1	141	38	179	38	50
ATV930U07N4	1	21	26	47	38	50
ATV930U15N4	1	41	28	69	38	50
ATV930U22N4	1	60	30	90	38	50
ATV930U30N4	1	78	31	109	38	50
ATV930U40N4	1	97	33	130	38	50
ATV930U55N4	1	145	36	182	38	50
ATV930U55M3	2	179	47	226	103	135
ATV930U75N4	2	172	44	216	103	135
ATV930D11N4	2	255	51	306	103	135
ATV930U75M3	3	310	51	361	103	135
ATV930D11M3	3	452	62	514	215	281
ATV930D15N4	3	366	59	425	215	281
ATV930D18N4	3	460	67	527	215	281
ATV930D22N4	3	505	68	573	215	281
ATV930D15M3	4	486	87	573	240	314
ATV930D18M3	4	595	97	691	240	314
ATV930D22M3	4	707	107	813	240	314
ATV930D30N4	4	640	93	733	240	314
ATV930D37N4	4	796	106	902	240	314
ATV930D45N4	4	943	121	1064	240	314
ATV930D30M3•	5	862	129	992	295	386
ATV930D37M3•	5	1141	156	1297	295	386
ATV930D45M3•	5	1367	175	1542	295	386
ATV930D55N4•	5	917	131	1048	295	386
ATV930D75N4•	5	1369	174	1543	295	386
ATV930D90N4•	5	1585	196	1781	295	386
ATV930D55M3C	6	2091	278	2369	600	785
ATV930D75M3C	6	2980	359	3339	600	785
ATV930C11N4C	6	2511	309	2820	600	785
ATV930C13N4C	6	2999	358	3357	600	785
ATV930C16N4C	6	3507	405	3912	600	785
ATV930C22N4	7	5030	451	5481	860	1125
ATV930C22N4C	7	5030	451	5481	860	1125
ATV930C25N4C	7	5773	606	6379	1260	1648
ATV930C31N4C	7	7099	769	7868	1260	1648

(1) First value is the power dissipated at nominal current in the forced cooled area of the drive. The second value is the power dissipated at nominal current in the natural cooled area, value used in case of installation using the flush-mounting kit, separate hot and control part in a cabinet. If the drive is installed in a standard cabinet, the sum of both values is to be taken into account.

Power Dissipated For Enclosed Drives and Required Air Flow - Floor Standing

Catalog Number ATV930 and ATV950	Power Dissipated in Normal Duty		Power Dissipated in Heavy Duty		Minimum air flow rate required per hour			
	Control Part only	Total Power	Control Part only	Total Power	Control Part		Power Part	
	(W)	(W)	(W)	(W)	(m ³)	(yd ³)	(m ³)	(yd ³)
C11N4F	380	2530	300	2010	140	184	580	759
C13N4F	450	3150	360	2520	140	184	580	759
C16N4F	560	4030	420	3120	140	184	580	759
C20N4F	580	4380	430	3380	140	184	1160	1518
C25N4F	730	5750	520	4340	140	184	1160	1518
C31N4F	990	7810	680	5700	140	184	1160	1518

Air flow Cooling Diagrams - Floor Standing

These diagrams show the cooling air flow.

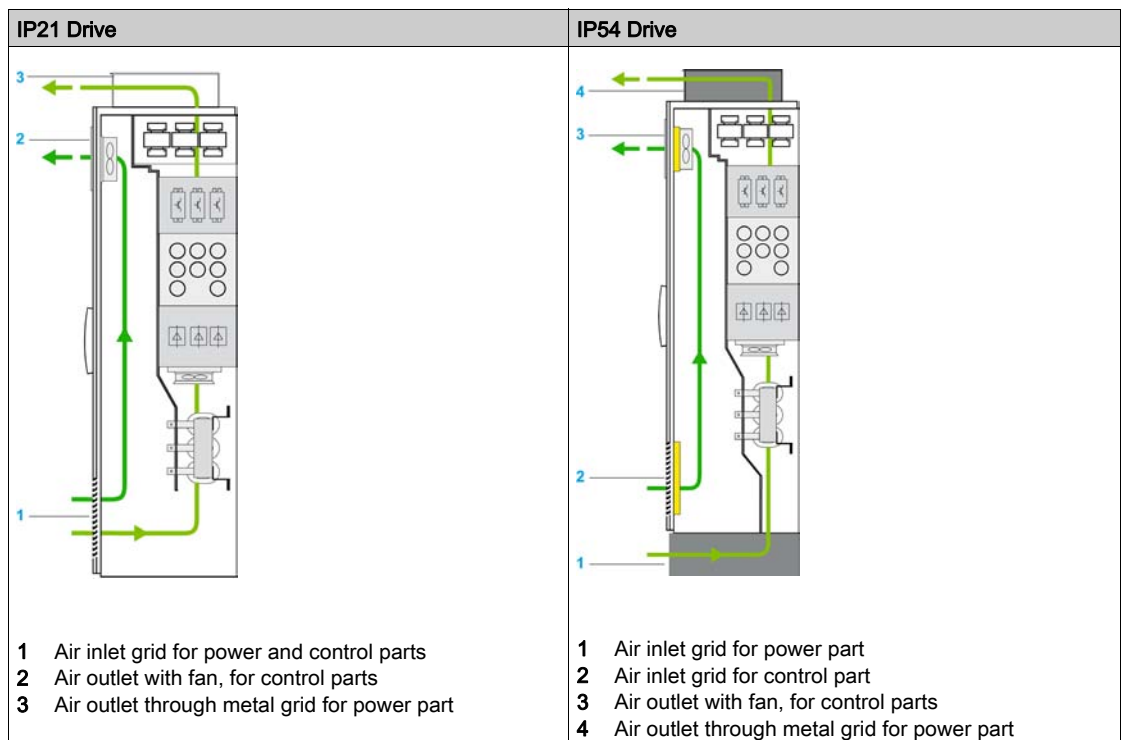

Derating Curves

Description

Derating curves for the nominal drive current (I_n) as a function of temperature and switching frequency. Refer to the Mounting Conditions chapter (*see page 65*) for the mounting types description.

Frame Size 1 - 200...240 V

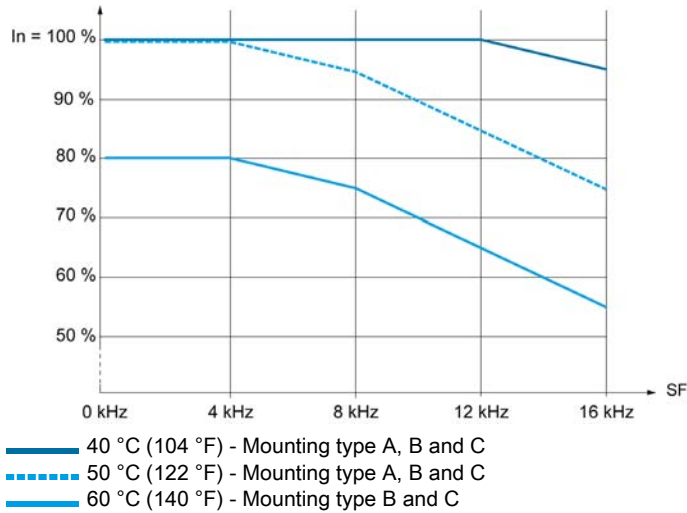

Frame Size 1 - 380...480 V

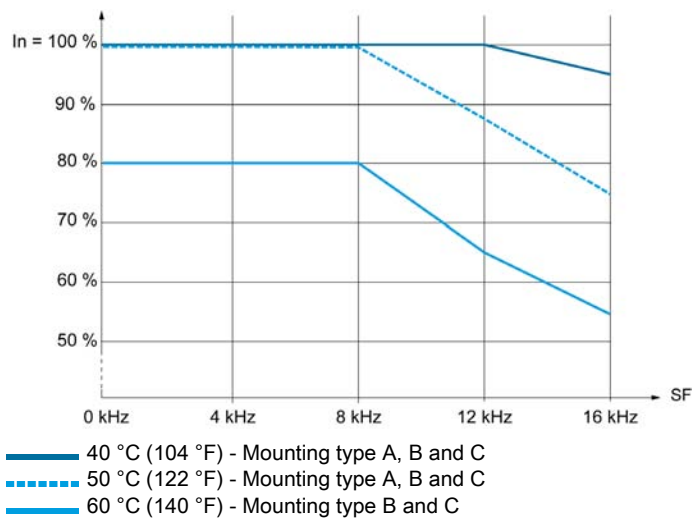

Frame Size 2 - 200...240 V

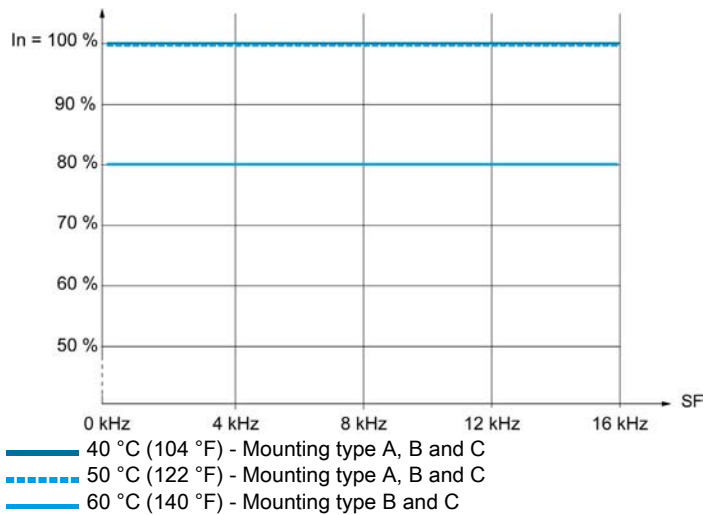

Frame Size 2 - 380...480 V

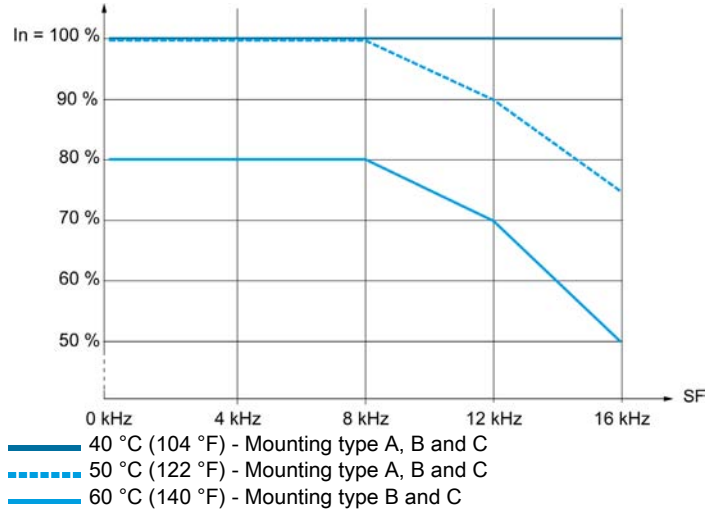

Frame Size 3 - 200...240 V

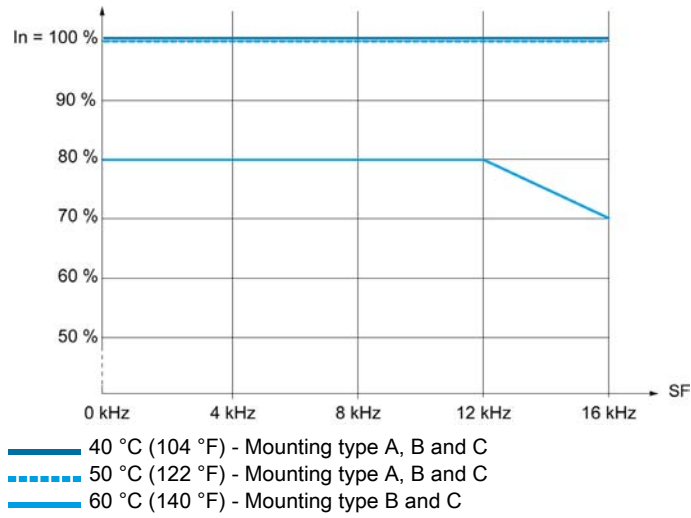

Frame Size 3 - 380...480 V

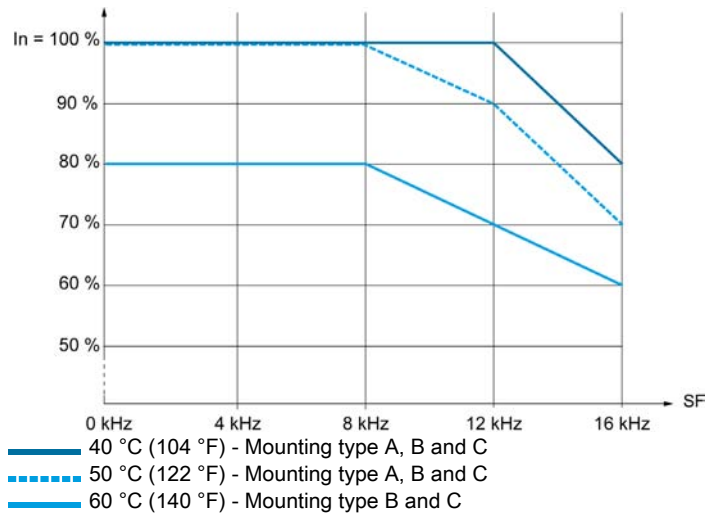

Frame Size 4 - 200...240 V

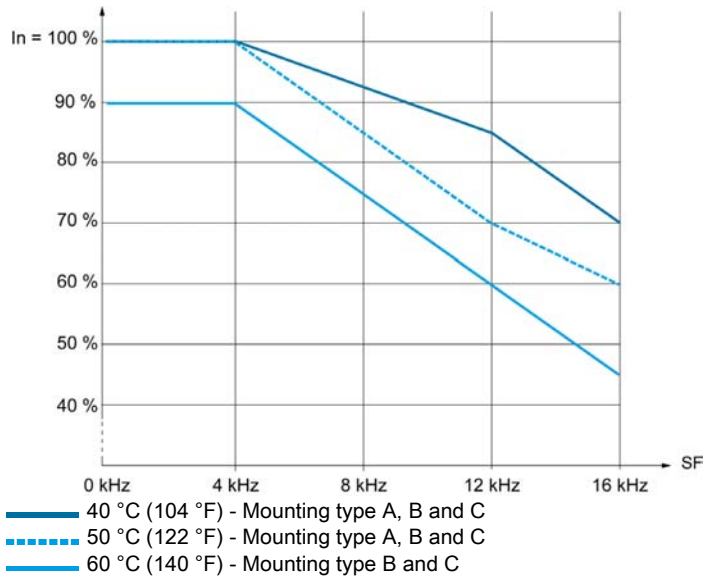

Frame Size 4 - 380...480 V

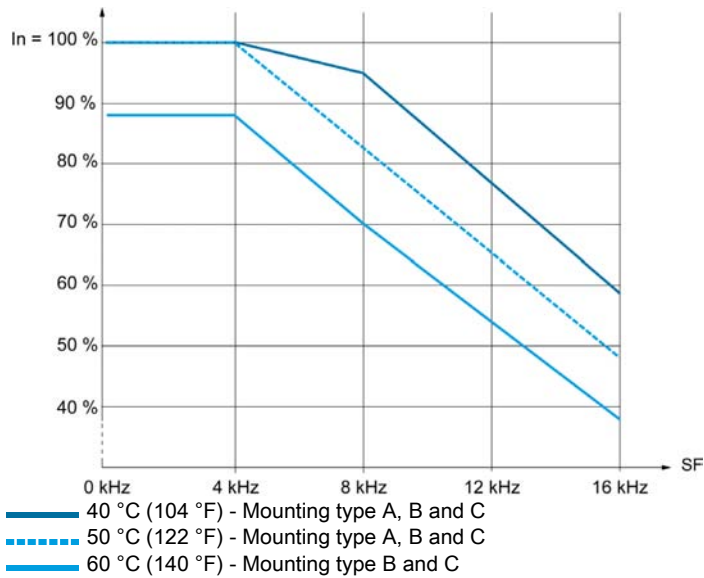

Frame Size 5 - 200...240 V

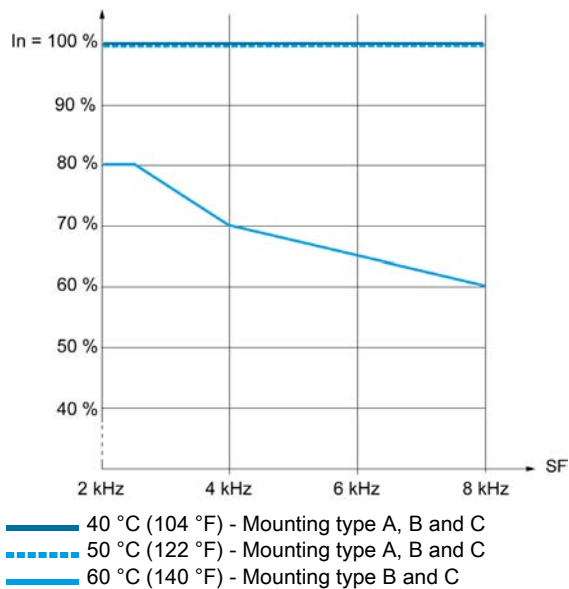

Frame Size 5 - 380...480 V -

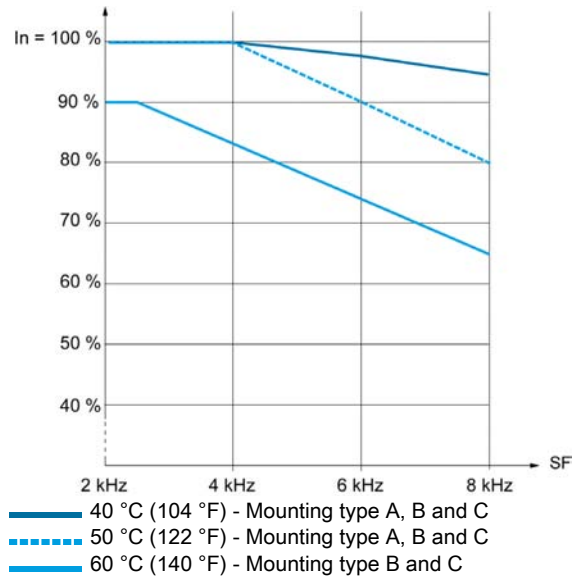

Frame Size 6 - 200...240 V and 380...480 V

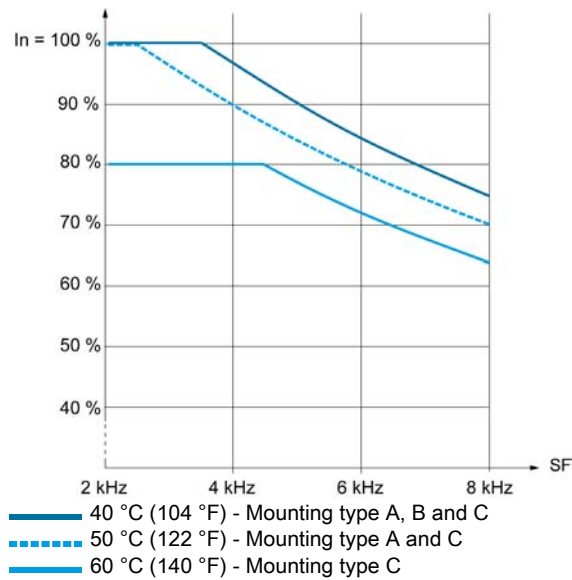

Frame Size 7a - 380...480 V - 220 kW

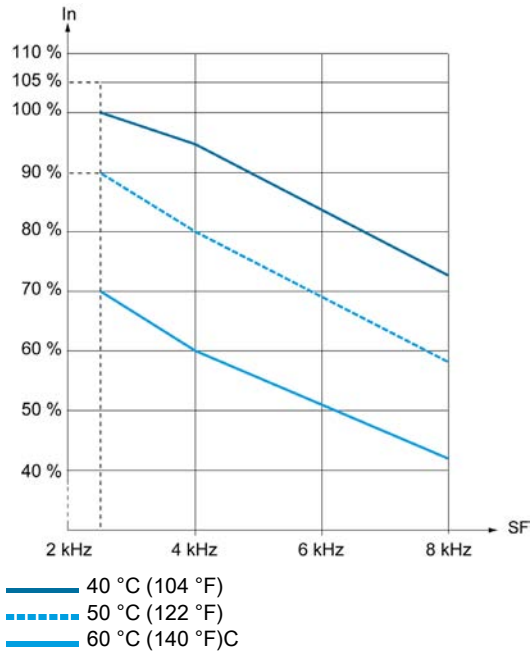

Frame Size 7b - 380...480 V - 250 kW

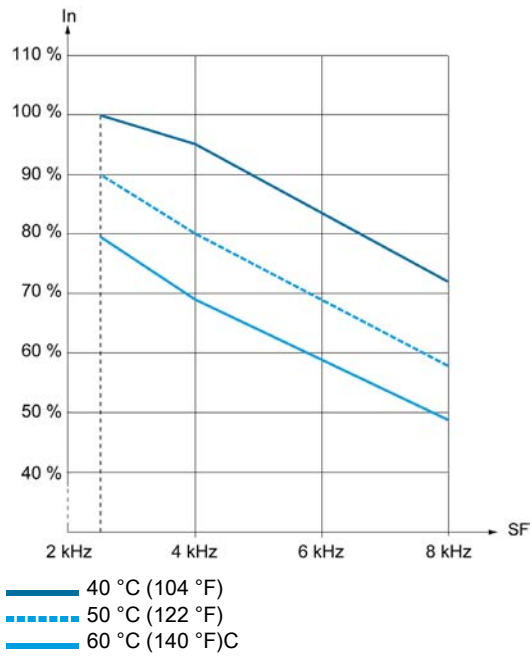

Frame Size 7b - 380...480 V - 315 kW

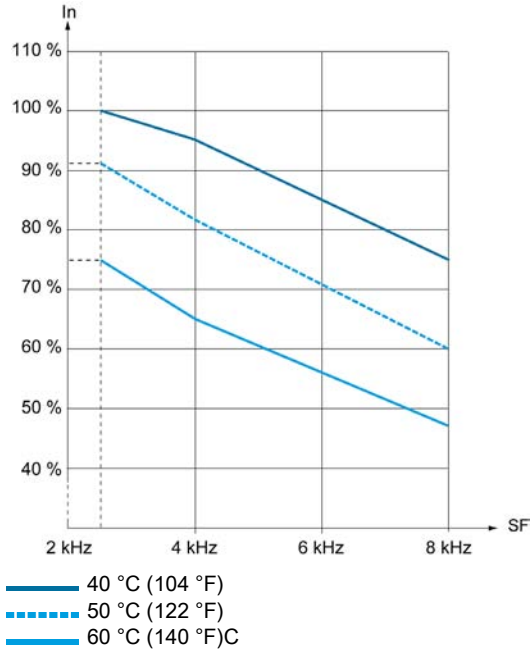

Frame Size SA up to ATV950D11N4

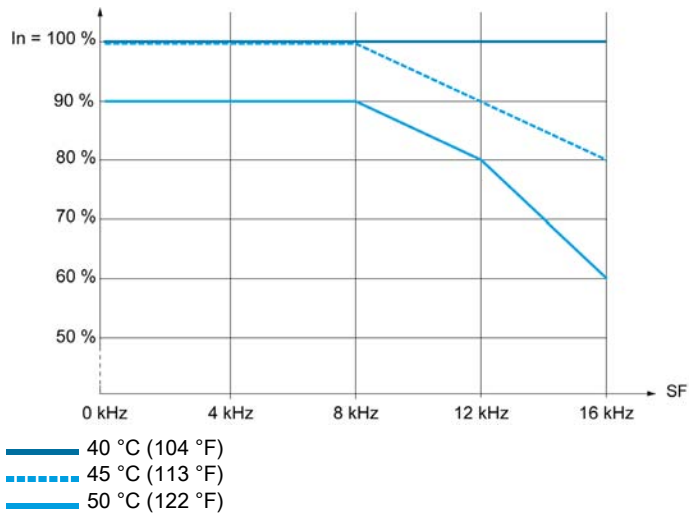

Frame Size SA, ATV950D15N4 to D22N4

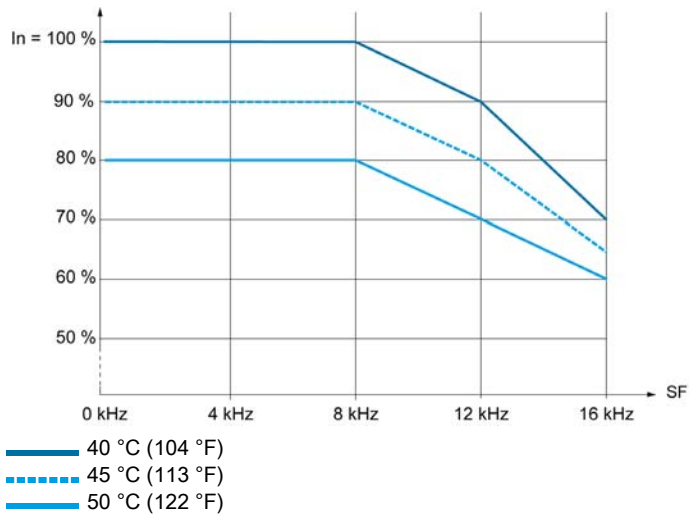

Frame Size SB

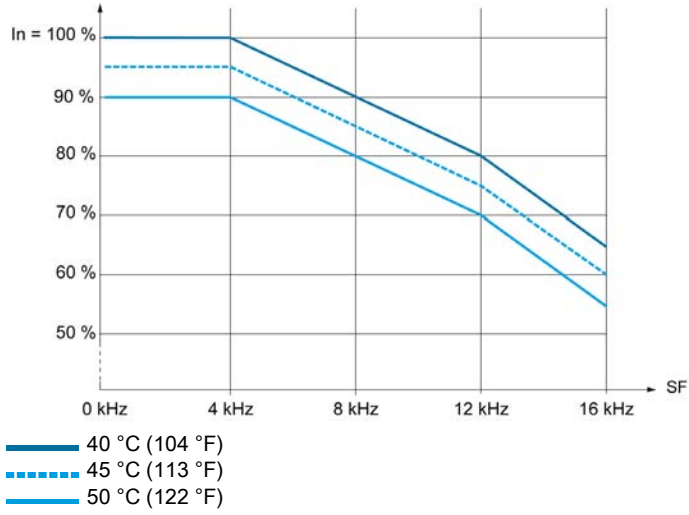

Frame Size SC

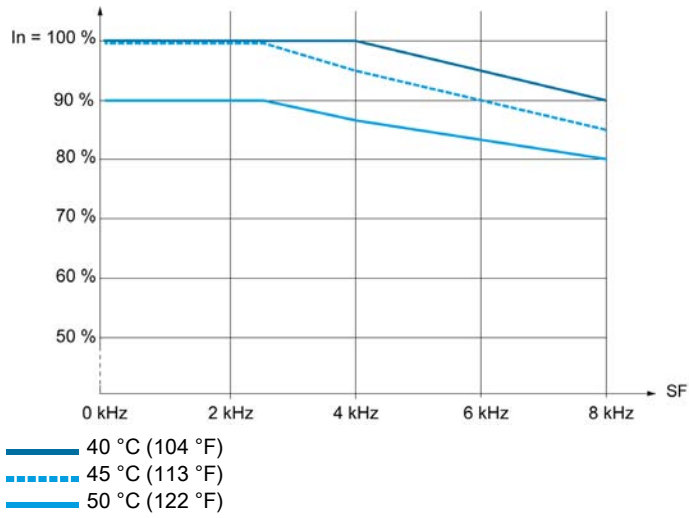

Floor Standing Drives - Frame Sizes FS1 and FS2 - 380...440 V - Normal Duty

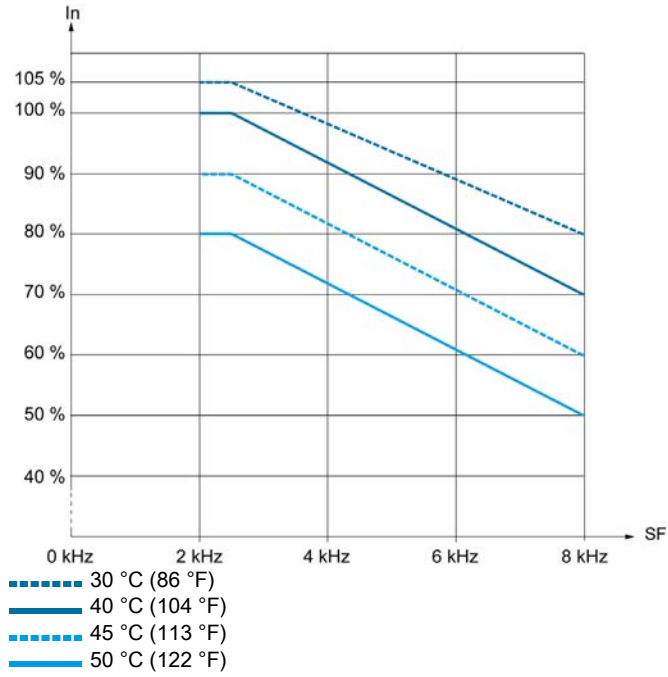

Floor Standing Drives - Frame Sizes FS1 and FS2 - 380...440 V - Heavy Duty

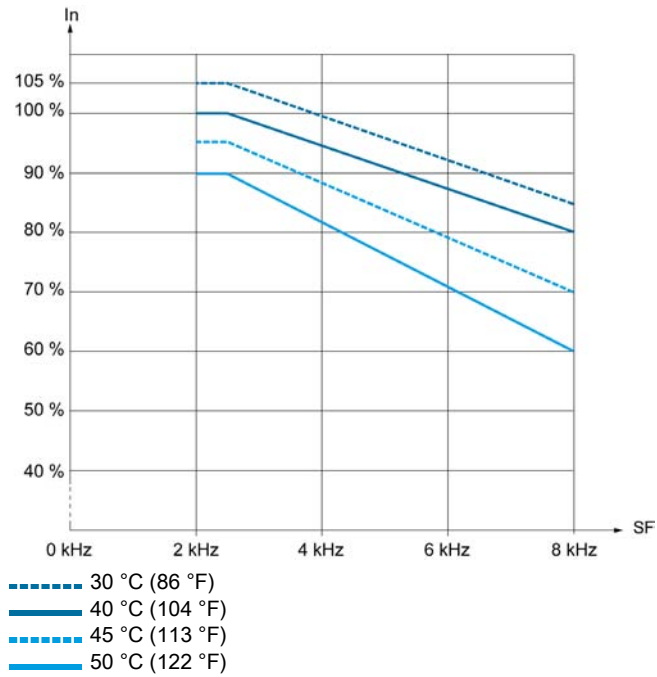

Mounting Procedures

Mounting Screws

Frame Size	Screw diameter	Hole diameter
1	5 mm (0.2 in)	6 mm (0.24 in)
2	5 mm (0.2 in)	6 mm (0.24 in)
3	5 mm (0.2 in)	6 mm (0.24 in)
4	6 mm (0.24 in)	7 mm (0.28 in)
5	8 mm (0.31 in)	9 mm (0.35 in)
6	10 mm (0.4 in)	11.5 mm (0.45 in)
7	10 mm (0.4 in)	11.5 mm (0.45 in)
A	5 mm (0.2 in)	6 mm (0.24 in)
B	8 mm (0.31 in)	9 mm (0.35 in)
C	10 mm (0.4 in)	11.6 mm (0.45 in)
Floor Standing	12 mm (0.47 in)	

Mounting Procedure For Frame Sizes 1 to 3

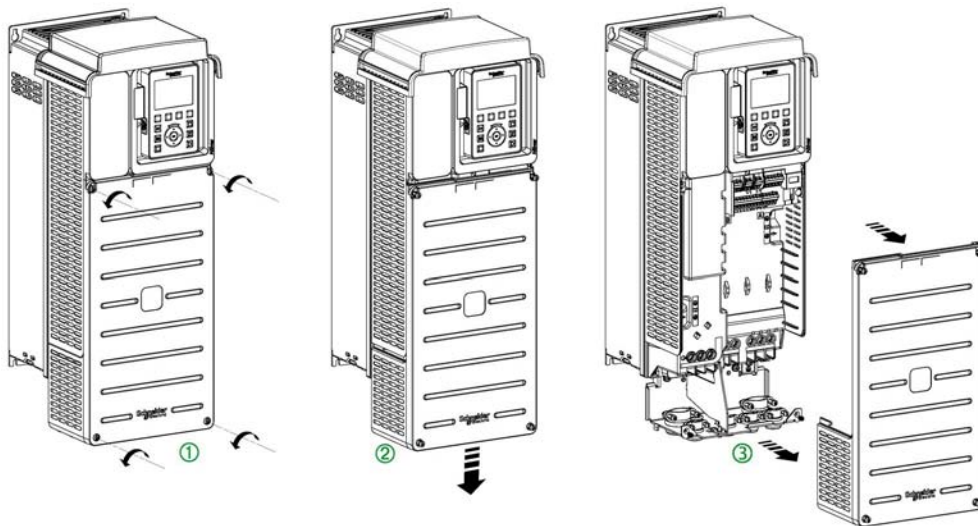

Perform the following instructions

Step	Action
1	Unscrew the 4 screws attaching the front cover
2	Slide down the front cover
3	Pull the front cover and remove it

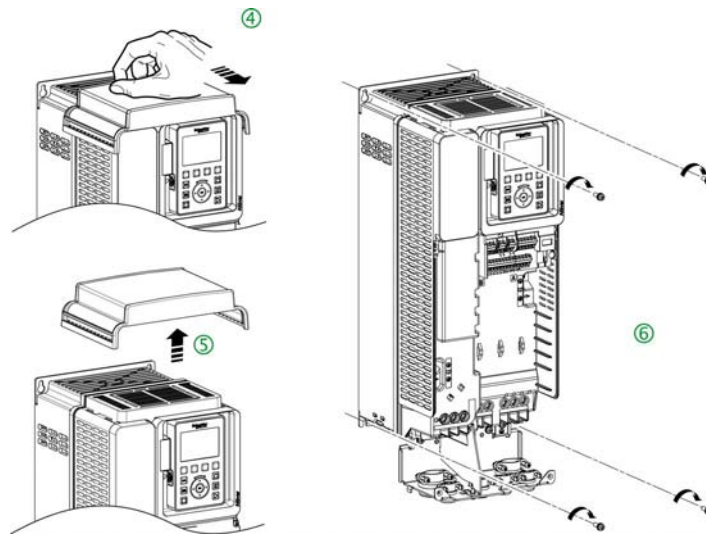

Perform the following instructions

Step	Action
1	Pull the top cover from back to front
2	Remove the top cover
3	Attach the drive on the mounting surface using the screws with captive washer, according to the table above (see page 80).
4	Refit the top cover to help prevent metal parts to fall into the drive during wiring operation or if IP21 degree of protection is requested.

Mounting Procedure For Frame Sizes 4 and 5

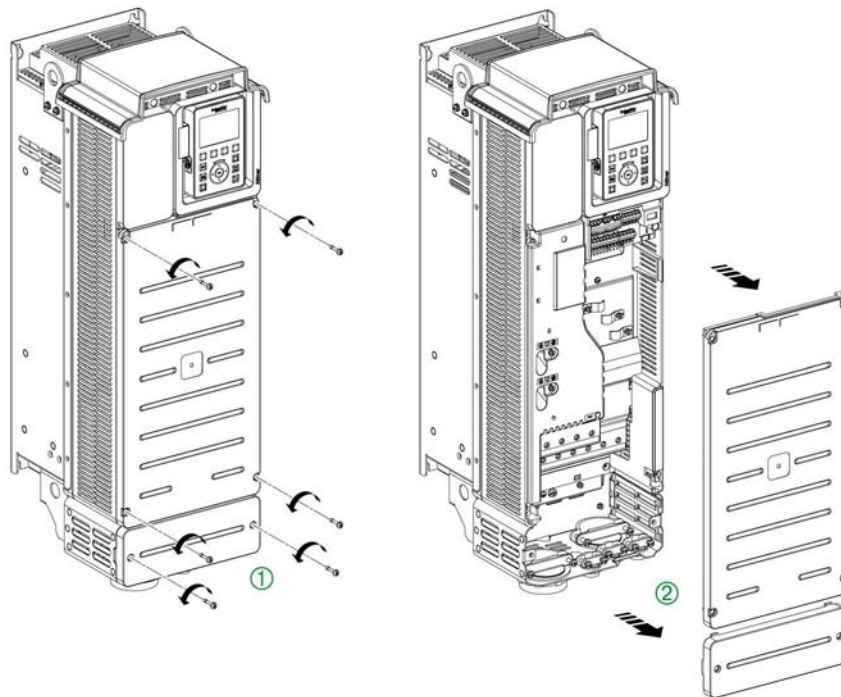

Perform the following instructions

Step	Action
1	Unscrew the 6 screws (frame size 4) or the 8 screws (frame size 5) attaching the front and bottom covers
2	Remove the covers

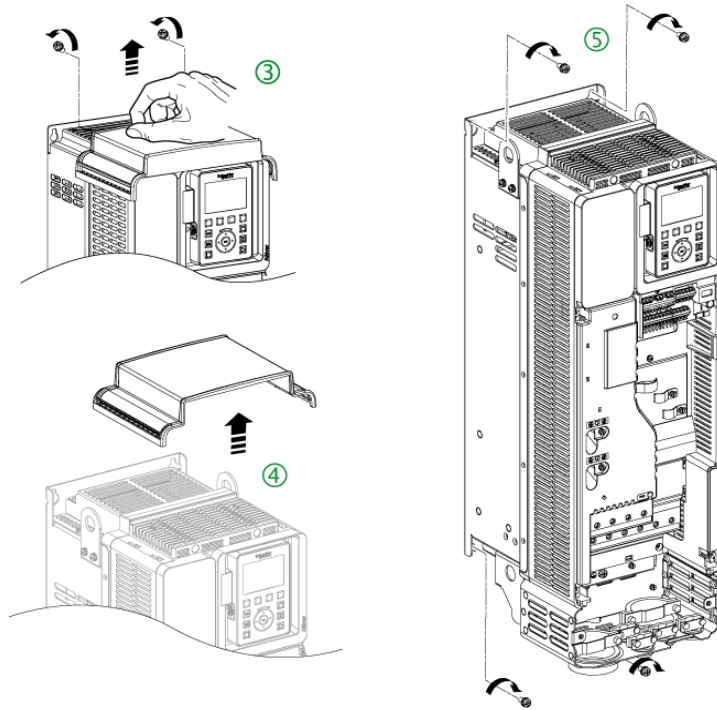

Perform the following instructions

Step	Action
1	For Size 5 products, unscrew the 2 screws underneath the top cover
2	Slide the top cover from back to front
3	Remove the top cover
4	Screw the drive on the mounting surface using 4 screws with captive washer, according to the table above (<i>see page 80</i>).
5	Refit the top cover on the drive.

Mounting Procedure For Frame Sizes 6 and 7

Mounting the drive does not require preliminary dismantling operation. Simply mount the drive to its support using the 4 screws with captive washer, according to the table above (*see page 80*).

Installing the DC choke on Frame Sizes 7 Drives

This should be performed after mounting the drive and before wiring it. If a braking module is being used, install the module on the drive before mounting the DC choke. During installation, ensure that no liquid, dust or conductive objects fall into the drive.

Perform the following instructions to install the DC chokes:

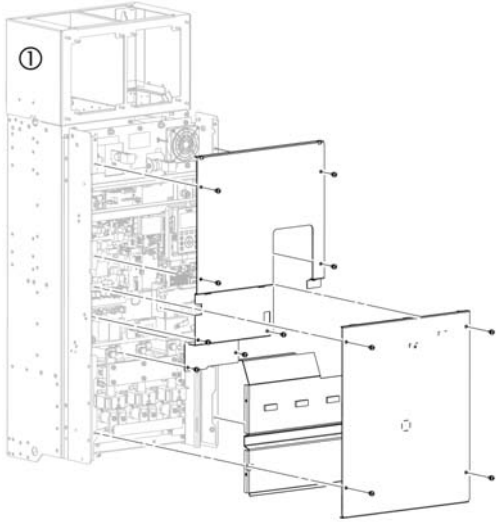
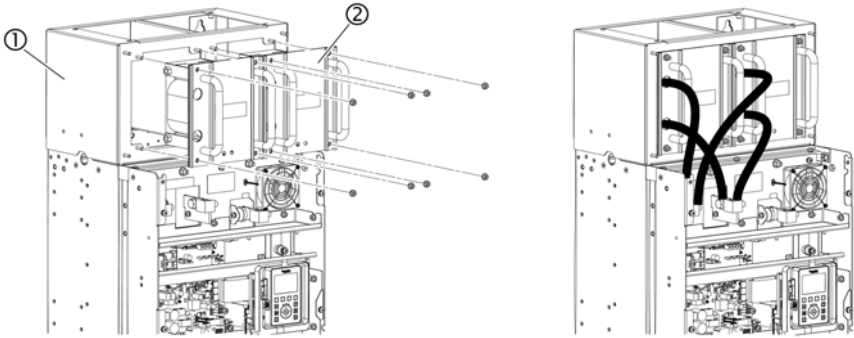
Step	Action
1	Mount the DC choke chassis ① on the wall, on top of the drive, using the 4 screws with captive washer, according to the table above. Ensure that the chassis is tightly secured to the drive to maintain the IP54 seal of the ventilation duct.
2	Remove the front covers 
3	Install the DC choke ② on the chassis ① using the 4 x M6 nuts provided. Tighten the nuts to 5.5 N·m (48.7 lb.in) 

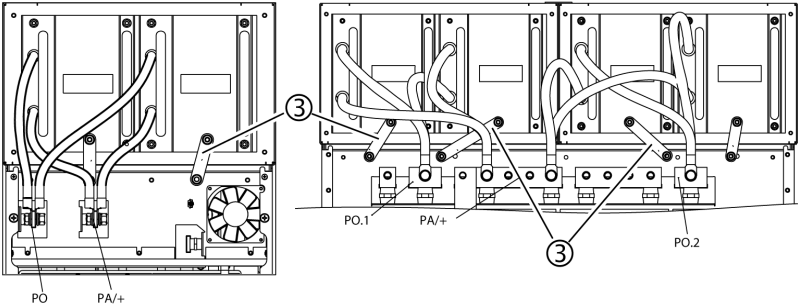
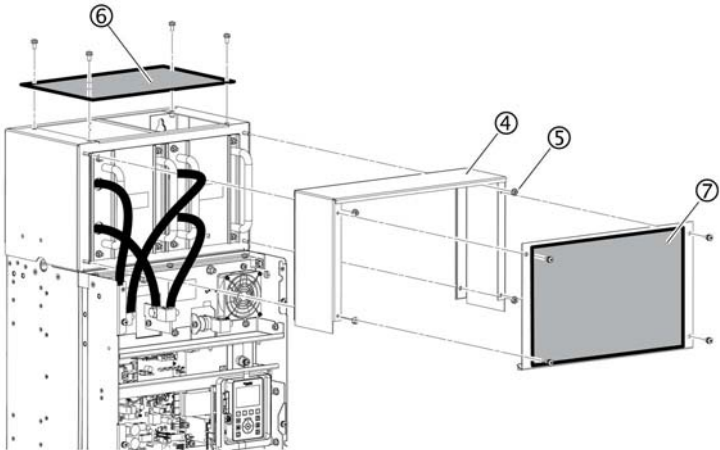
Step	Action
4	<p>Connect the choke between the PO and PA/+ terminals on the drive using M12 screws. Tighten the screws to 45 N·m (398 lb.in) Example of cabling for frame size 7a (on the left) and frame size 7b</p>  <p>Connect the grounding strips ③ between the DC choke chassis ① and the drive using M8 nuts. Tighten the nuts to 13.5 N·m (119.5 lb.in).</p>
5	<p>Mount the cover ④ on the chassis and secure it with the nuts ⑤ provided.</p>  <p>Mount panels ⑥ and ⑦ using the screws provided. Tighten the M6 nuts to 5.5 N·m (48.7 lb.in).</p>
6	<p>Refit all the drive covers. Tighten the M5 nuts to 3.5 N·m (30.9 lb.in).</p>

NOTE:

- Once the choke has been installed, the degree of protection of the top of the drive is IP31.
- The number of DC chokes supplied with the drive varies according to the drive rating.

Mounting Procedure For Frame Sizes A, B and C

Mounting the drive does not require preliminary dismantling operation. Simply mount the drive to its support using the 4 screws with captive washer, according to the table above (*see page 80*).

Floor Standing Drives

NOTE: Installation and mounting procedures of the floor standing drives are described in the dedicated instruction sheet [NVE57369](#) delivered with these drives and available on schneider-electric.com.

Chapter 4

Drive wiring

What Is in This Chapter?

This chapter contains the following topics:

Topic	Page
Wiring Instructions	86
Specific Wiring Instructions For Wall Mounting Drives	88
Specific Wiring Instructions For Floor Standing Drives	89
Dimensioning Of Power Part Cables For Floor Standing Drives	90
Cable Length Instructions	92
Wiring Diagrams	94
Sink / Source Switch Configuration	97
Pulse Train Output / Digital Output Switch Configuration	98
Characteristics of the Power Part Terminals	99
Wiring the Power Part	106
Electromagnetic Compatibility	119
Operation on an IT or Corner Grounded System	121
Disconnecting The Built-in EMC Filter	121
Control Terminals Electrical Data	126
Arrangement and Characteristics of Control Block Terminals and Communication and I/O Ports	129
Wiring The Control Part	131

Wiring Instructions

General Instructions

 DANGER
HAZARD OF FIRE OR ELECTRIC SHOCK <ul style="list-style-type: none">• Wire cross sections and tightening torques must comply with the specifications provided in this document• Do not use multi-conductor cables without cable lugs for any connection with a voltage higher than 25 Vac. Failure to follow these instructions will result in death or serious injury.

Cable Characteristics

If you are using cables longer than 150 m (492 ft) between the drive and the motor, add output filters (for more details refer to the catalog).

Use a shielded cable to meet the requirements of Category C2 or C3 according to the standard IEC 61800-3, except when using a sinus filter. In this case, the use of a non-shielded motor cable is possible.

To limit the currents in common mode, use common mode output filters (ferrite) in order to reduce the circulating currents in the motor windings.

Standard linear capacity cables can be used with Altivar Process. Use of cables with lower linear capacity could increase cable length performances.

The overvoltage limitation function [**Motor surge limit.**] $5 \mu L$ enables you to increase the cable length while decreasing the torque performances (refer to Programming manual EAV64318).

Power and Circuit Protection

Where local and national codes require upstream protection with a residual current device, use a type A-Si device.

Choose a suitable model integrating:

- High frequency current filtering,
- A time delay that helps to prevent a triggering of the upstream device caused by the load from stray capacitance on power-on. The time delay is not available for 30 mA device; in this case, choose devices with immunity against nuisance triggering.

Due to high leakage current in standard operation, we recommend to choose at least a 300 mA device.

If the installation requires a residual current device less than 300 mA, it can be possible to use a device lower than 300 mA by removing the screws according to the instructions given in the Disconnecting The Built-in EMC Filter section (*see page 121*).

If the installation includes several drives, provide one residual current device per drive.

Control

 WARNING
UNEXPECTED EQUIPMENT OPERATION <p>Wire the digital and analog inputs and outputs only with the specified shielded, twisted cables.</p> Failure to follow these instructions can result in death, serious injury, or equipment damage.

- Keep the control circuits away from the power cables. For digital and analog inputs/outputs, use shielded twisted cables with a pitch of 25...50 mm (1 in. and 2 in.)
- It is recommended to use cable ends, available on www.schneider-electric.com.

Residual Current Device

Direct current can be introduced in the protective ground conductor of this drive. If a residual current device (RCD / GFCI) or a residual current monitor (RCM) is used for additional protection against direct or indirect contact, the following specific types must be used.

WARNING

DIRECT CURRENT CAN BE INTRODUCED INTO THE PROTECTIVE GROUND CONDUCTOR

- Use a Type A Residual Current Device (RCD / GFCI) or a Residual Current Monitor (RCM) for single-phase drives connected to a phase and to the neutral conductor.
- Use a Type B Residual Current Device (RCD / GFCI) or a Residual Current Monitor (RCM) that has approval for use with frequency inverters and is sensitive to all types of current for three-phase devices and for single-phase devices not connected to a phase and the neutral conductor.

Failure to follow these instructions can result in death, serious injury, or equipment damage.

Further conditions for use of a residual current device:

- The drive has an increased leakage current at the moment power is applied. Use a residual current device (RCD / GFCI) or a residual current monitor (RCM) with a response delay.
- High-frequency currents must be filtered.

Equipment Grounding

NOTICE

DESTRUCTION DUE TO INCORRECT WIRING

- Before switching on and configuring the product, verify that it is properly wired.

Failure to follow these instructions can result in equipment damage.

DANGER

ELECTRIC SHOCK CAUSED BY INSUFFICIENT GROUNDING

- Verify compliance with all local and national electrical code requirements as well as all other applicable regulations with respect to grounding of the entire drive system.
- Ground the drive system before applying voltage.
- The cross section of the protective ground conductor must comply with the applicable standards.
- Do not use conduits as protective ground conductors; use a protective ground conductor inside the conduit.
- Do not consider cable shields to be protective ground conductors.

Failure to follow these instructions will result in death or serious injury.

Tighten the grounding screws according to the instructions given in the Ground Cables section ([see page 99](#)).

Specific Wiring Instructions For Wall Mounting Drives

Connection Instructions

The product has a leakage current greater than 3.5 mA. If the protective ground connection is interrupted, a hazardous touch current may flow if the product is touched.

⚠️ ⚠️ DANGER

ELECTRIC SHOCK CAUSED BY HIGH LEAKAGE CURRENT

- Verify compliance with all local and national electrical code requirements as well as all other applicable regulations with respect to grounding of the entire drive system.

Failure to follow these instructions will result in death or serious injury.

⚠️ WARNING

INSUFFICIENT PROTECTION AGAINST OVERCURRENTS

- Properly rated overcurrent protective devices must be used.
- Use the fuses specified in the annex provided with the drive.
- Do not connect the product to a supply mains whose short-circuit current rating (SCCR) exceeds the permissible value specified in the annex provided with the drive.

Failure to follow these instructions can result in death, serious injury, or equipment damage.

- Ensure that the resistance to Ground is 1 Ohm or less.
- When grounding several drives, you must connect each one directly, as shown in the above figure.
- Do not loop Ground cables or connect them in series.

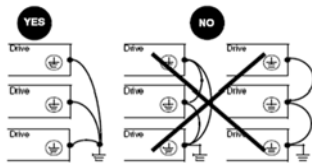

Specific Wiring Instructions For Floor Standing Drives

Protective Grounding

There is a marked terminal (bar) inside the enclosure to connect the protective conductor. Furthermore there is a marked terminal (bar) to connect the protective grounding of the motor.

The product has a leakage current greater than 3.5 mA. If the protective ground connection is interrupted, a hazardous touch current may flow if the product is touched.

DANGER

ELECTRIC SHOCK CAUSED BY HIGH LEAKAGE CURRENT

- Verify compliance with all local and national electrical code requirements as well as all other applicable regulations with respect to grounding of the entire drive system.

Failure to follow these instructions will result in death or serious injury.

Connection Instructions

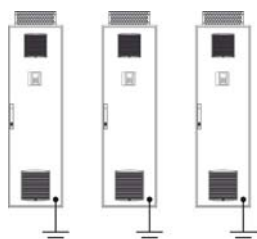

- Check whether the resistance of the protective grounding is 0.1 Ω or less.
- When several inverters need to be connected to the protective ground, each one must be connected directly to this protective ground as illustrated above.

Dimensioning Of Power Part Cables For Floor Standing Drives

Cable Cross Sections



The recommended values for dimensioning the cable cross sections given in chapter Characteristics of the Power Part Terminals (*see page 99*) are reference values for multi-core copper power cables laid in air at a maximum ambient temperature of 40°C (104°F). Observe different ambient conditions and local regulations.

Dimensioning of the Supply Mains Cables

⚠ WARNING
OVERLOAD BECAUSE OF INCORRECT RATING OF MAINS SUPPLY
<ul style="list-style-type: none"> • Provide fuses or circuit breakers at the mains to protect the mains cable and the main switch inside the floor standing drive. • Obey the available mains short circuit current (50 kVA) when dimensioning the mains pre-fuses, mains cable cross sections and mains cable lengths. • Increase the power of the transformer, if required, to reach the necessary short-circuit current of 50 kVA.
Failure to follow these instructions can result in death, serious injury, or equipment damage.

The Floor standing drives include semiconductor fuses as standard (*see page 61*).

Types of Supply Mains Cables

Cable Type	Description
	Three-phase cable with sector-shaped conductors and reduced protective conductor. NOTE: Verify that the PE conductor complies with the requirements according to IEC 61439-1.
	Three-phase cable with round conductors and reduced protective conductor. NOTE: Verify that the PE conductor complies with the requirements according to IEC 61439-1.





Dimensioning of the Motor Cables

⚠ WARNING
OVERLOAD DUE TO WRONG MOTOR CABLE
Only use symmetrical motor cables (see standard IEC 60034-25).
Failure to follow these instructions can result in death, serious injury, or equipment damage.

The motor cables are dimensioned for the maximum continuous current. They apply to 0...100 Hz (up to 300 Hz the cable losses increase about 25 % because of the Skin-effect).

The IGBT modules cause high-frequent interferences which drain off more and more stronger to the ground potential with increasing motor cable length. As a result the line-conducted interferences to the mains increase. In case of too long motor cables the attenuation of the mains filters is not longer sufficient and the permitted interference limits are exceeded.

Types of Motor Cables

Cable Type	Description
	<p>Symmetrically shielded cable with 3 phase conductors, symmetrically arranged PE conductor  and a shield.</p> <p>NOTE: Verify that the PE conductor complies with the requirements according to IEC 61439-1.</p> <p>Example: 2YSLCY-JB</p>
	<p>Symmetrically shielded cable with 3 phase conductors and a concentric PE conductor  as shield.</p> <p>NOTE: Verify that the PE conductor complies with the requirements according to IEC 61439-1.</p> <p>Example: NYCY / NYCWY</p>
	<p>Three-phase cable with round conductors and reduced protective conductor.</p> <p>NOTE: A separate PE conductor is required if the shield does not fulfill the requirements according to IEC 61439-1.</p>

Cable Length Instructions

Long Cable Lengths Consequences

When drives are used with motors, a combination of fast switching transistors and long motor cables can even cause peak voltages up to twice the DC link voltage. This high peak voltage can cause premature aging of motor winding insulation which leads to motor breakdown.

The overvoltage limitation function will enable to increase the cable length while decreasing the torque performances.

Length Of Motor Cables

Because of the permitted mains disturbances, the allowed overvoltages at the motor, the occurring bearing currents and the permitted heat losses the distance between inverter and motor(s) is limited.

The maximum distance heavily depends on the used motors (insulation material), the type of motor cable used (shielded/unshielded), the cable laying (cable channel, underground installation...) as well as from the used options.

Dynamic Voltage Load Of The Motor

Overvoltages at the motor terminals result from reflection in the motor cable. Basically the motors are stressed with measurable higher voltage peaks from a motor cable length of 10 m. With the length of the motor cable also the value of overvoltage increases.

The steep edges of the switching impulses at the output side of the frequency inverter lead to a further load of the motors. The slew rate of the voltage is typically over 5 kV/μs but it decreases with the length of the motor cable

Load of the motor with overvoltage and slew rate when using conventional drive

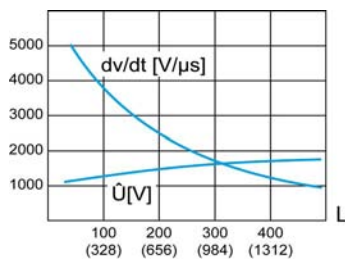

L Length of motor cables in meters (feet)

Corrective Actions Overview

A number of simple measures can be taken to help enhance the motor life time:

- Specification of a motor designed for speed drive applications (IEC60034-25 B or NEMA 400 should be prescribed).
- Specification of drives that integrate voltage reflection superimposition software suppression. Refer to **[Volt surge limit. opt] 5 ▫ P** parameter in the Altivar Process ATV930, ATV950, ATV960 Programming manual [NHA80757](#).
- Reduce to a minimum the distance between motor and drive.
- Use unshielded cables.
- Reduce the drive switching frequency (a reduction to 2.5 kHz is recommended.)

Preventive Measures Suitable for Wall Mounting Drives According to IEC60034-25

The preventive measures will depend on motor characteristics and cable length.

Motor cable length (unshielded cable)	Motor conforming to IEC60034-25	Motor NOT-conforming to IEC60034-25
1 m (3 ft) < L < 50 m (164 ft)	Filter not required	dV/dt filter
50 m (164 ft) < L < 100 m (328 ft)	Filter not required	Sinus filter
100 m (328 ft) < L < 300 m (984 ft)	Filter not required	Sinus filter
300 m (984 ft) < L < 500 m (1640 ft)	dV/dt filter	Sinus filter
500 m (1640 ft) < L < 1000 m (3281 ft)	Sinus filter	Sinus filter

NOTE: When calculating cable lengths for the purpose of guarding against these overvoltage situations, a shielded cable should count as twice the length of an unshielded cable. For example, if a shielded cable is 100 m (328 ft) in actual length, it should be considered to be equal to a 200 m (656 ft) length standard cable in the calculation.

NOTE: The FS drive is delivered with standard output filters. For motor cable lengths beyond 300 m (984 ft), refer to the ATV660 drive range.

Additional Information

Further detailed technical information is available in the following white paper *An Improved Approach for Connecting VSD and Electric Motors* available on www.schneider-electric.com.

Wiring Diagrams

Control Block Wiring Diagram

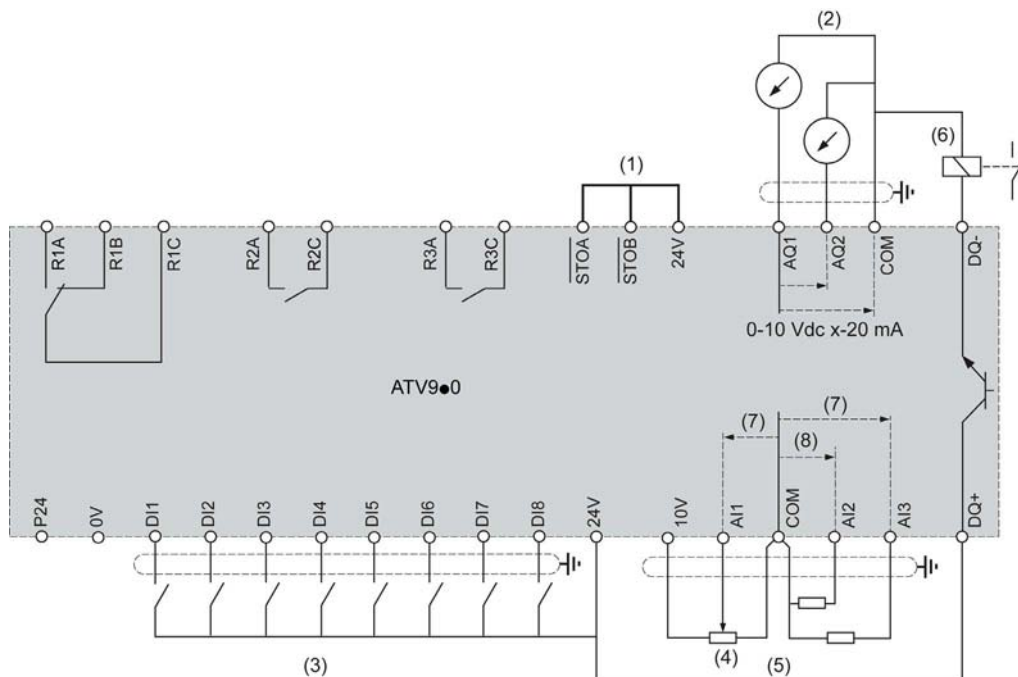

(1) STO Safe Torque Off, (2) Analog Output, (3) Digital Input - Shielding instructions are given in the Electromagnetic Compatibility section (*see page 119*) (4) reference potentiometer (ex. SZ1RV1002), (5) Analog Input, (6) Digital output, (7) 0-10 Vdc, x-20 mA, (8) 0-10 Vdc, -10 Vdc...+10 Vdc.

Three-phase Power Supply - Diagram With Line Contactor Without Safety Function STO

Connection diagrams conforming to standards ISO13849 category 1 and IEC/EN 61508 capacity SIL1, stopping category 0 in accordance with standard IEC/EN 60204-1.

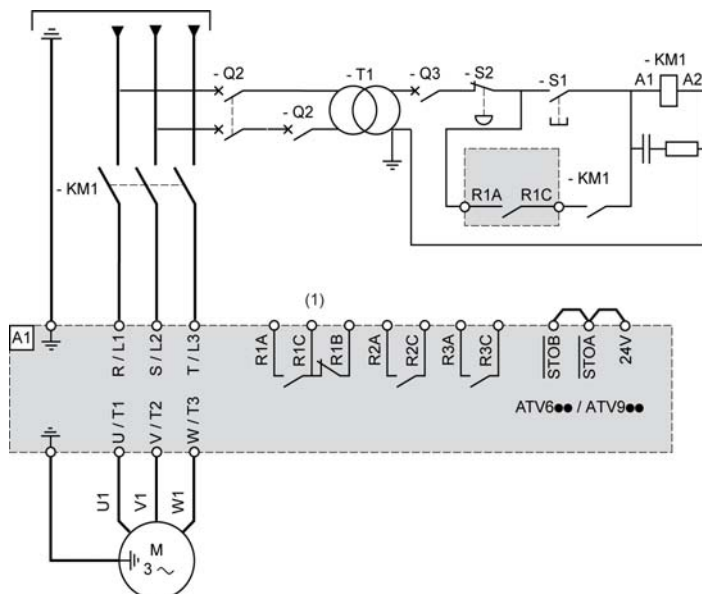

(1) Use relay output R1 set to operating state Fault to switch Off the product once an error is detected.

Single or Three-phase Power Supply - Diagram With Downstream Contactor

If a Run command is executed while the downstream contactor between the drive and the motor is still open, there may be residual voltage at the output of the drive. This can cause an incorrect estimation of the motor speed when the contacts of the downstream contactor are closed. This incorrect estimation of the motor speed can lead to unanticipated equipment operation or to equipment damage.

In addition, there may be overvoltage at the output of the drive if the power stage is still enabled when the downstream contactor between the drive and the motor opens.

⚠ WARNING

UNANTICIPATED EQUIPMENT OPERATION OR EQUIPMENT DAMAGE

If a downstream contactor is used between the drive and the motor, verify the following:

- The contacts between the motor and the drive must be closed before a Run command is executed.
- The power stage must not be enabled when the contacts between the motor and the drive open.

Failure to follow these instructions can result in death, serious injury, or equipment damage.

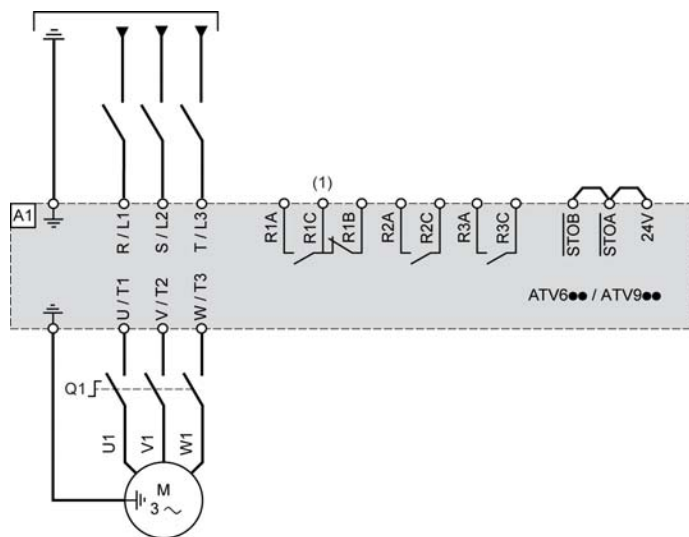

(1) Use relay output R1 set to operating state Fault to switch Off the product once an error is detected.

Safety Function STO

All details related to the STO safety function activation are given in the ATV900 Embedded Safety Function Manual [NHA80947](#).

Sensor Connection

It is possible to connect either 1 or 3 sensors on terminals A11 or A13.

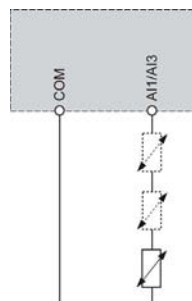

Floor Standing Drive Circuit Diagram

The following diagram shows the typical wiring of the drive.

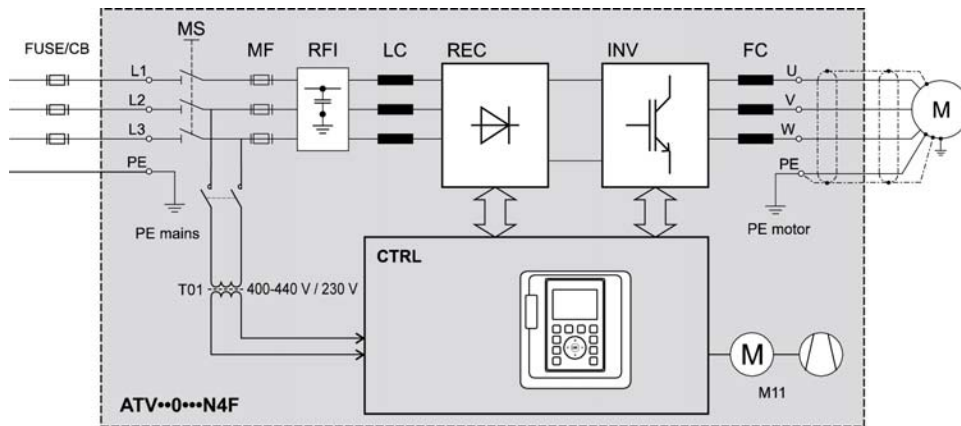

ATV00N4F Altivar Process Floor standing drive

FUSE/CB External pre-fuse or circuit breaker to protect the mains cable

MS Built-in main switch, lockable in open position (only available on IP54 drives)

T01 Control transformer 400 / 230 V AC

MF aR fuses for short-circuit shut-down if the electronic protective devices do not work properly

RFI Built-in RFI filter, considering category C3 according to EN 61800-3 *Use in industrial environments*

LC Line reactor to reduce the current harmonics on the mains caused by the DC link

REC Rectifier module(s)

INV Inverter module(s)

FC dv/dt filter choke to reduce the voltage load of the motor

CTRL Control panel with control block and further control components

M11 Fan in enclosure door

If the internal circuit breaker is open, the internal fans will not be supplied. If the door is not completely closed, the cooling system will not operate properly. This may cause the drive to trigger an overtemperature error.

NOTICE

OVERHEATING AND DAMAGE TO THE DRIVE SYSTEM

- Verify that the circuit breaker accessible inside the cabinet is always closed during operation.
- Verify that the door of the cabinet is always closed during operation.

Failure to follow these instructions can result in equipment damage.

Sink / Source Switch Configuration

⚠ WARNING

UNANTICIPATED EQUIPMENT OPERATION

- If the drive is set to **Sink Int** or **Sink Ext**, do not connect the 0 V terminal to ground or to protective ground.
- Verify that accidental grounding of digital inputs configured for sink logic, caused, for example, by damage to the signal cables, cannot occur.
- Follow all applicable standards and directives such as NFPA 79 and EN 60204 for proper control circuit grounding practices.

Failure to follow these instructions can result in death, serious injury, or equipment damage.

The switch is used to adapt the operation of the logic inputs to the technology of the programmable controller outputs. To access the switch, follow the Access to control Terminals procedure ([see page 131](#)). The switch is located below the control terminals ([see page 130](#)).

- Set the switch to Source (factory setting) if using PLC outputs with PNP transistors.
- Set the switch to Ext if using PLC outputs with NPN transistors.

Switch Set to SRC (Source) Position Using the Output Power Supply for the Digital Inputs

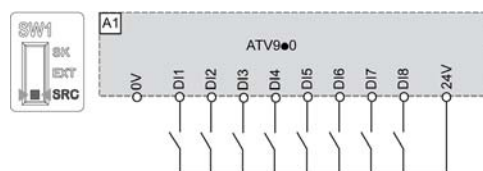

Switch Set to SRC (Source) Position and Use of an External Power Supply for the DIs

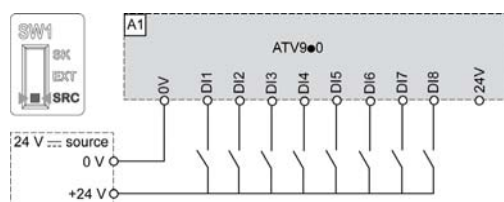

Switch Set to SK (Sink) Position Using the Output Power Supply for the Digital Inputs

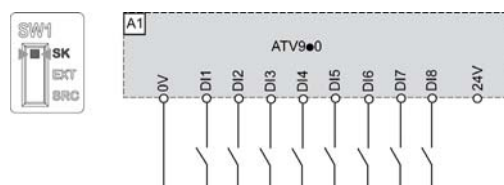

Switch Set to EXT Position Using an External Power Supply for the DIs

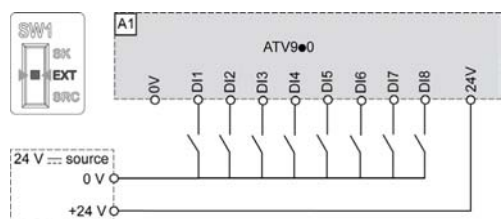

NOTE:

- STO inputs are also connected by default on a 24 Vdc terminal. If the external power supply is switched off, the function STO will be triggered.
- To avoid to trigger the STO function when switching-on the product, the external power supply must be previously switched on.

Pulse Train Output / Digital Output Switch Configuration

Purpose

⚠ WARNING

UNANTICIPATED EQUIPMENT OPERATION

- If the drive is set to **Sink Int** or **Sink Ext**, do not connect the 0 V terminal to ground or to protective ground.
- Verify that accidental grounding of digital inputs configured for sink logic, caused, for example, by damage to the signal cables, cannot occur.
- Follow all applicable standards and directives such as NFPA 79 and EN 60204 for proper control circuit grounding practices.

Failure to follow these instructions can result in death, serious injury, or equipment damage.

The SW2 (PTO/DQ) switch is used to configure the DQ+ or DQ- digital outputs.

- Set the switch to **PTO (Pulse Train Output)** to configure DQ+ and DQ- outputs as pulse train outputs. This may be used to chain pulse train inputs of another drive, using its DI7 or DI8 pulse inputs.
- Set the switch to **DQ (Digital Output)** to configure DQ+ and DQ- outputs as an assignable logic output.

Access

To access the switch, follow the Access to control Terminals procedure ([see page 131](#)). The switch is located below the control terminals ([see page 130](#)).

Switch SW1 Set to SK (Sink mode) Position

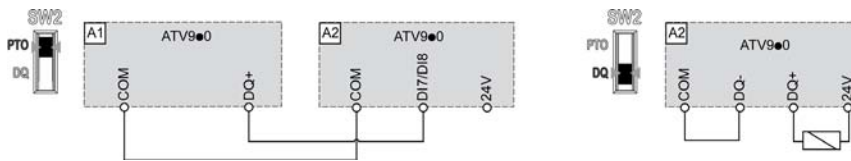

Switch SW1 Set to EXT (Sink ext mode) Position

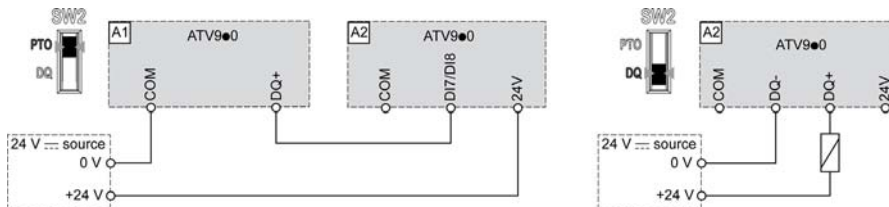

Switch SW1 Set to SRC (Source mode) Position

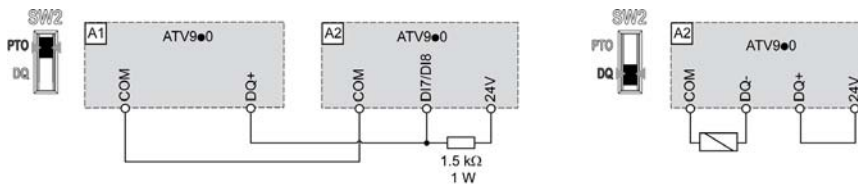

Switch SW1 Set to SRC (Source ext mode) Position

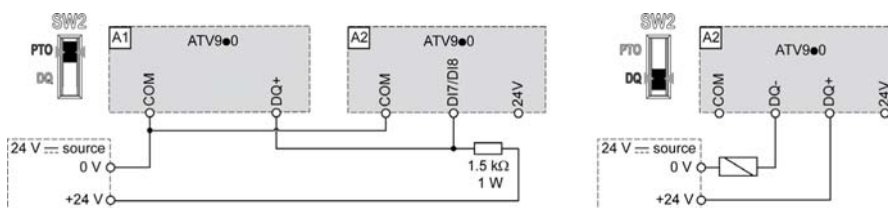

Characteristics of the Power Part Terminals

Ground Cables

Ground cable cross sections of input and output ground cables are the same as those given for the input and output cables. Minimum cross section of protective ground cable is 10 mm² (AWG 8) and 16 mm² (AWG 6) for AL cable.

Tightening torques according to frame size

- Frame sizes 1...3: 2.5 N·m (22.1 lb.in)
- Frame size 4: 5 N·m (44.2 lb.in)
- Frame size 5: 10 N·m (88.5 lb.in)
- Frame size 6:
 - ①: 27 N·m (239 lb.in)
 - ②: 13.5 N·m (119.5 lb.in)

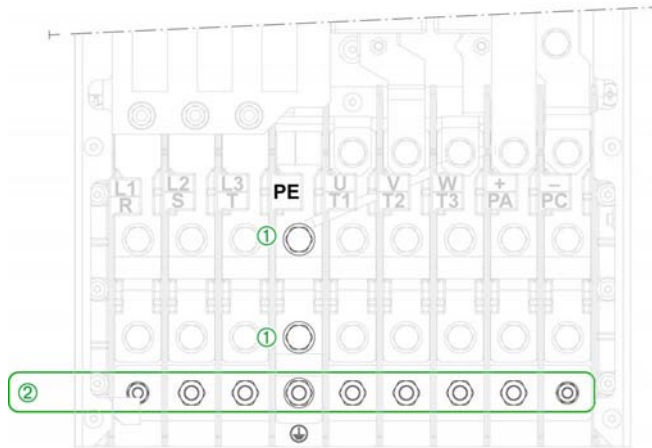

Frame Size 1

Supply and Output Terminals

ATV930	Supply Terminals (L1, L2, L3)			Output Terminals (U, V, W)		
	Wire Cross Section		Tightening Torque	Wire Cross Section		Tightening Torque
	Minimum	Maximum (*)	Rated	Minimum	Maximum (*)	Rated
	mm ² (AWG)	mm ² (AWG)	N·m (lb.in)	mm ² (AWG)	mm ² (AWG)	N·m (lb.in)
U07••, U15••, U22••, U30N4, U40N4	2.5 (14)	6 (10)	1.3 (11.5)	2.5 (14)	6 (10)	1.3 (11.5)
U55N4, U30M3	2.5 (14)	6 (10)	1.3 (11.5)	4 (12)	6 (10)	1.3 (11.5)
U40M3	4 (12)	6 (10)	1.3 (11.5)	6 (10)	6 (10)	1.3 (11.5)

(*) maximum permissible cross section of the terminal

DC Bus Terminals

ATV930	DC Bus Terminals (PA+, PB, PC-)		
	Wire Cross Section		Tightening Torque
	Minimum	Maximum (*)	Rated
	mm ² (AWG)	mm ² (AWG)	N·m (lb.in)
U07••N4...U55••N4, U07M3...U30M3	2.5 (14)	6 (10)	1.3 (11.5)
U40M3	4 (12)	6 (10)	1.3 (11.5)

(*) maximum permissible cross section of the terminal

Frame Size 2

Supply and Output Terminals

ATV930	Supply Terminals (L1, L2, L3)			Output Terminals (U, V, W)		
	Wire Cross Section		Tightening Torque	Wire Cross Section		Tightening Torque
	Minimum	Maximum (*)	Rated	Minimum	Maximum (*)	Rated
	mm ² (AWG)	mm ² (AWG)	N·m (lb.in)	mm ² (AWG)	mm ² (AWG)	N·m (lb.in)
U75N4	4 (12)	6 (10)	1.8 (15.6)	6 (10)	10 (8)	1.8 (15.6)
D11N4	6 (10)	6 (10)	1.8 (15.6)	6 (10)	10 (8)	1.8 (15.6)
U55M3	6 (10)	6 (10)	1.8 (15.6)	10 (8)	10 (8)	1.8 (15.6)

(*) maximum permissible cross section of the terminal

DC Bus Terminals

ATV930	DC Bus Terminals (PA+, PB, PC/-)		
	Wire Cross Section		Tightening Torque
	Minimum	Maximum (*)	Rated
	mm ² (AWG)	mm ² (AWG)	N·m (lb.in)
U75N4	4 (12)	6 (10)	1.8 (15.6)
U55M3...D11N4	6 (10)	6 (10)	1.8 (15.6)

(*) maximum permissible cross section of the terminal

Frame Size 3

Supply and Output Terminals

ATV930	Supply Terminals (L1, L2, L3)			Output Terminals (U, V, W)		
	Wire Cross Section		Tightening Torque	Wire Cross Section		Tightening Torque
	Minimum	Maximum (*)	Rated	Minimum	Maximum (*)	Rated
	mm ² (AWG)	mm ² (AWG)	N·m (lb.in)	mm ² (AWG)	mm ² (AWG)	N·m (lb.in)
D15N4, D18N4, U75M3	10 (8)	16 (6)	3.5 (30.4)	10 (8)	16 (6)	3.5 (30.4)
D22N4, D11M3	10 (8)	16 (6)	3.5 (30.4)	16 (6)	16 (6)	3.5 (30.4)

(*) maximum permissible cross section of the terminal

DC Bus Terminals

ATV930	DC Bus Terminals (PA+, PB, PC/-)		
	Wire Cross Section		Tightening Torque
	Minimum	Maximum (*)	Rated
	mm ² (AWG)	mm ² (AWG)	N·m (lb.in)
D15N4...D22N4, U75M3...D11M3	10 (8)	16 (6)	2.5 (22.1)

(*) maximum permissible cross section of the terminal

Frame Size 4

Supply and Output Terminals

ATV930	Supply Terminals (L1, L2, L3)			Output Terminals (U, V, W)		
	Wire Cross Section		Tightening Torque	Wire Cross Section		Tightening Torque
	Minimum	Maximum (*)	Rated	Minimum	Maximum (*)	Rated
	mm ² (AWG)	mm ² (AWG)	N·m (lb.in)	mm ² (AWG)	mm ² (AWG)	N·m (lb.in)
D30N4, D15M3	25 (4)	50 (1)	5 (44.3)	25 (4)	50 (1)	5 (44.3)
D37N4, D18M3	35 (3)	50 (1)	5 (44.3)	35 (3)	50 (1)	5 (44.3)
D45N4, D22M3	35 (2)	50 (1)	5 (44.3)	50 (1)	50 (1)	10 (88.5)

(*) maximum permissible cross section of the terminal

DC Bus Terminals

ATV930	DC Bus Terminals (PA+, PB, PC/-)		
	Wire Cross Section		Tightening Torque
	Minimum	Maximum (*)	Rated
	mm ² (AWG)	mm ² (AWG)	N·m (lb.in)
D30N4...D37N4, D15M3...D18M3	25 (4)	50 (1)	5 (44.3)
D45N4, D22M3	35 (3)	50 (1)	5 (44.3)

(*) maximum permissible cross section of the terminal

Frame Size 5

Supply and Output Terminals

ATV930	Supply Terminals (L1, L2, L3)			Output Terminals (U, V, W)		
	Wire Cross Section		Tightening Torque	Wire Cross Section		Tightening Torque
	Minimum	Maximum (*)	Min. to Maximum	Minimum	Maximum (*)	Rated
	mm ² (AWG)	mm ² (AWG)	N·m (lb.in)	mm ² (AWG)	mm ² (AWG)	N·m (lb.in)
D55N4•	70 (1/0)	120 (250MCM)	10 (88.5)	70 (1/0)	120 (250MCM)	10 (88.5)
D30M3•	70 (1/0)	120 (250MCM)	10 (88.5)	70 (2/0)	120 (250MCM)	18 (159.3)
D75N4•	95 (3/0)	120 (250MCM)	18 (159.3)	95 (3/0)	120 (250MCM)	18 (159.3)
D37M3•	70 (2/0)	120 (250MCM)	18 (159.3)	95 (3/0)	120 (250MCM)	18 (159.3)
D90N4•, D45M3•	120 (4/0)	120 (250MCM)	18 (159.3)	120 (250MCM)	120 (250MCM)	18 (159.3)

(*) maximum permissible cross section of the terminal

DC Bus Terminals

ATV930	DC Bus Terminals (PA+, PB, PC/-)		
	Wire Cross Section		Tightening Torque
	Minimum	Maximum (*)	Rated
	mm ² (AWG)	mm ² (AWG)	N·m (lb.in)
D55N4•...D75N4•, D30M3•	70 (1/0)	120 (250MCM)	10 (88.5)
D37M3•	70 (2/0)	120 (250MCM)	18 (159.3)
D90N4•	95 (3/0)	120 (250MCM)	18 (159.3)
D45M3•	120 (4/0)	120 (250MCM)	18 (159.3)

(*) maximum permissible cross section of the terminal

Frame Size 6

NOTE: if used with ring tongue: selection criteria are compatible with screw M10, width 24 mm (0.94 in.), following DIN 46234.

Supply and Output Terminals

AT930	Supply Terminals (L1, L2, L3)			Output Terminals (U, V, W)		
	Wire Cross Section		Tightening Torque	Wire Cross Section		Tightening Torque
	Minimum	Maximum (*)	Rated	Minimum	Maximum (*)	Rated
	mm ² (AWG)	mm ² (AWG)	N·m (lb.in)	mm ² (AWG)	mm ² (AWG)	N·m (lb.in)
C11N4C	2 x 50 (2 x 1/0)	3 x 120 (2 x 300MCM)	27 (239)	2 x 50 (2 x 1/0)	3 x 120 (2 x 300MCM)	27 (239)
C13N4C, D55M3C	2 x 70 (2 x 2/0)	3 x 120 (2 x 300MCM)	27 (239)	2 x 70 (2 x 2/0)	3 x 120 (2 x 300MCM)	27 (239)
C16N4C, D75M3C	2 x 95 (2 x 3/0)	3 x 120 (2 x 300MCM)	27 (239)	2 x 95 (2 x 3/0)	3 x 120 (2 x 300MCM)	27 (239)

(*) maximum permissible cross section of the terminal

DC Bus Terminals

ATV930	DC Bus Terminals (PA/+, PB, PC/-)		
	Wire Cross Section		Tightening Torque
	Minimum	Maximum (*)	Rated
	mm ² (AWG)	mm ² (AWG)	N·m (lb.in)
C11NC	2 x 50 (2 x 1/0)	3 x 120 (2 x 300MCM)	27 (239)
C13NC, D55M3C	2 x 70 (2 x 2/0)	3 x 120 (2 x 300MCM)	27 (239)
C16NC, D75M3C	2 x 95 (2 x 3/0)	3 x 120 (2 x 300MCM)	27 (239)

(*) maximum permissible cross section of the terminal

Frame Size 7

Supply and Output Terminals

AT930	Supply Terminals (L1, L2, L3)			Output Terminals (U, V, W)		
	Wire Cross Section		Tightening Torque	Wire Cross Section		Tightening Torque
	Minimum	Maximum (*)	Rated	Minimum	Maximum (*)	Rated
	mm ² (AWG)	mm ² (AWG)	N·m (lb.in)	mm ² (AWG)	mm ² (AWG)	N·m (lb.in)
C22N4, C22N4C	2 x 150 (2 x 350MCM)	2 x 150 (2 x 350MCM)	41 (360)	2 x 150 (2 x 350MCM)	2 x 150 (2 x 350MCM)	41 (360)
C25N4C, C31N4C	4 x 185 (3 x 350MCM)	4 x 185 (3 x 350MCM)	41 (360)	4 x 185 (3 x 350MCM)	4 x 185 (3 x 350MCM)	41 (360)

(*) maximum permissible cross section of the terminal

DC Bus Terminals

ATV930	DC Bus Terminals (PA/+, PB, PC/-)		
	Wire Cross Section		Tightening Torque
	Minimum	Maximum (*)	Rated
	mm ² (AWG)	mm ² (AWG)	N·m (lb.in)
C22N4, C22N4C	2 x 150 (2 x 350MCM)	2 x 150 (2 x 350MCM)	41 (360)
C25N4C, C31N4C	2 x 150 (2 x 350MCM)	2 x 150 (2 x 350MCM)	41 (360)

(*) maximum permissible cross section of the terminal

Frame Size A

Supply and Output Terminals

ATV950	Supply Terminals (L1, L2, L3)			Output Terminals (U, V, W)		
	Wire Cross Section		Tightening Torque	Wire Cross Section		Tightening Torque
	Minimum	Maximum (*)	Rated	Minimum	Maximum (*)	Rated
	mm ² (AWG)	mm ² (AWG)	N·m (lb.in)	mm ² (AWG)	mm ² (AWG)	N·m (lb.in)
U07N4...U55N4	4 (12)	6 (10)	1.3 (11.5)	4 (12)	6 (10)	1.3 (11.5)
U07N4E...U55N4E	4 (N/A)	6 (N/A)	2.1 (18.3)	4 (N/A)	6 (N/A)	1.3 (11.5)
U75N4	4 (12)	6 (10)	1.8 (15.6)	6 (10)	10 (8)	1.8 (15.6)
U75N4E	4 (N/A)	6 (N/A)	2.1 (18.3)	6 (N/A)	10	1.8 (15.6)
D11N4	6 (10)	6 (10)	1.8 (15.6)	6 (10)	10 (8)	1.8 (15.6)
D11N4E	6 (N/A)	6 (N/A)	2.1 (18.3)	6 (N/A)	10 (N/A)	1.8 (15.6)
D15N4, D18N4	10 (8)	16 (6)	3.5 (30.4)	10 (8)	16 (6)	3.5 (30.4)
D15N4E, D18N4E	10 (N/A)	16 (N/A)	4.5 (40)	10 (N/A)	16 (N/A)	3.5 (30.4)
D22N4	10 (8)	16 (6)	3.5 (30.4)	16 (6)	16 (6)	3.5 (30.4)
D22N4E	10 (N/A)	16 (N/A)	4.5 (40)	16 (N/A)	16 (N/A)	3.5 (30.4)

(*) maximum permissible cross section of the terminal

DC Bus Terminals

ATV950	DC Bus Terminals (PA/+, PB, PC/-)		
	Wire Cross Section		Tightening Torque
	Minimum	Maximum (*)	Rated
	mm ² (AWG)	mm ² (AWG)	N·m (lb.in)
U07N4•...U55N4•	2.5 (14)	6 (10)	1.3 (11.5)
U75N4•	4 (12)	10 (8)	1.8 (15.6)
D11N4•	6 (10)	10 (8)	1.8 (15.6)
D15N4•...D22N4•	10 (8)	16 (6)	3.5 (30.4)

(*) maximum permissible cross section of the terminal

Frame Size B

Supply and Output Terminals

ATV950	Supply Terminals (L1, L2, L3)			Output Power Terminals (U, V, W)		
	Wire Cross Section		Tightening Torque	Wire Cross Section		Tightening Torque
	Minimum	Maximum (*)	Rated	Minimum	Maximum (*)	Rated
	mm ² (AWG)	mm ² (AWG)	N·m (lb.in)	mm ² (AWG)	mm ² (AWG)	N·m (lb.in)
D30N4	25 (4)	50 (1)	5 (44.3)	25 (4)	50 (1)	5 (44.3)
D30N4E	25 (N/A)	50 (N/A)	22.6 (200)	25 (N/A)	50 (N/A)	5 (44.3)
D37N4	25 (4)	50 (1)	5 (44.3)	35 (3)	50 (1)	5 (44.3)
D37N4E	25 (N/A)	50 (N/A)	22.6 (200)	35 (N/A)	50 (N/A)	5 (44.3)
D45N4	35 (3)	50 (1)	5 (44.3)	35 (2)	50 (1)	5 (44.3)
D45N4E	35 (N/A)	50 (N/A)	22.6 (200)	35 (N/A)	50 (N/A)	5 (44.3)

(*) maximum permissible cross section of the terminal

DC Bus Terminals

ATV950	DC Bus Terminals (PA/+, PB, PC/-)		
	Wire Cross Section		Tightening Torque
	Minimum	Maximum (*)	Rated
	mm ² (AWG)	mm ² (AWG)	N·m (lb.in)
D30N4•...D37N4•	25 (4)	50 (1)	5 (44.3)
D45N4•	35 (3)	50 (1)	5 (44.3)

(*) maximum permissible cross section of the terminal

Frame Size C

Supply and Output Terminals

ATV950	Supply Terminals (L1, L2, L3)			Output Terminals (U, V, W)		
	Wire Cross Section		Tightening Torque	Wire Cross Section		Tightening Torque
	Minimum	Maximum (*)	Rated	Minimum	Maximum (*)	Rated
	mm ² (AWG)	mm ² (AWG)	N·m (lb.in)	mm ² (AWG)	mm ² (AWG)	N·m (lb.in)
D55N4	50 (1)	120 (250MCM)	10 (88.5)	70 (1/0)	120 (250MCM)	10 (88.5)
D55N4E	70 (N/A)	95 (N/A)	22.6 (200)	70 (N/A)	120 (N/A)	10 (88.5)
D75N4	70 (2/0)	120 (250MCM)	18 (159.3)	95 (3/0)	120 (250MCM)	18 (159.3)
D75N4E	95 (N/A)	95 (N/A)	22.6 (200)	95 (N/A)	120 (N/A)	18 (159.3)
D90N4	95 (3/0)	120 (250MCM)	18 (159.3)	120 (4/0)	120 (250MCM)	18 (159.3)
D90N4E	95 (N/A)	95 (N/A)	22.6 (200)	120 (N/A)	120 (N/A)	18 (159.3)

(*) maximum permissible cross section of the terminal

DC Bus Terminals

ATV950	DC Bus Terminals (PA/+, PB, PC/-)		
	Wire Cross Section		Tightening Torque
	Minimum	Maximum (*)	Rated
	mm ² (AWG)	mm ² (AWG)	N·m (lb.in)
D55N4•	50 (1)	120 (250MCM)	10 (88.5)
D75N4•	70 (1/0)	120 (250MCM)	10 (88.5)
D90N4•	95 (3/0)	120 (250MCM)	18 (159.3)

(*) maximum permissible cross section of the terminal

Floor Standing Drives

Supply and Output Terminals

ATV930 and ATV950	Supply (L1, L2, L3) and Output (U, V, W) Terminals	Tightening Torque
	Maximum Wire Cross Section	N·m (lb.in)
C11N4F...C16N4F	M12 bar, 1 or 2 x 185 mm ²	47 (115)
C20N4F...C31N4F	M12 bar, 3 or 4 x 185 mm ²	47 (115)

Wiring the Power Part

Access To The Terminals For Frame Sizes 1 to 3

DANGER

HAZARD OF ELECTRIC SHOCK, EXPLOSION OR ARC FLASH

Read and understand the instructions in **Safety Information** chapter before performing any procedure in this chapter.

Failure to follow these instructions will result in death or serious injury.

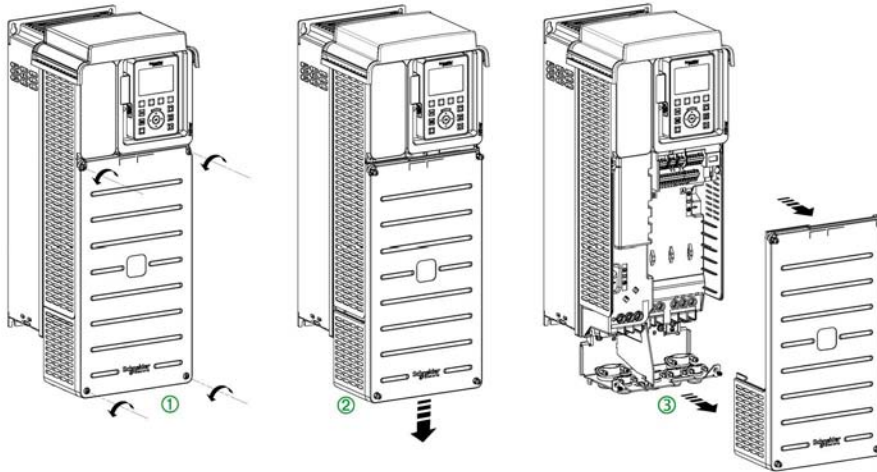

Apply the following instructions to access the terminals on **frame sizes 1 to 3** drives

Step	Action
1	Unscrew the 4 screws attaching the housing
2	Slide down the front cover
3	Remove the front cover

Access To The Terminals For Frame Sizes 4 and 5

DANGER

HAZARD OF ELECTRIC SHOCK, EXPLOSION OR ARC FLASH

Read and understand the instructions in **Safety Information** chapter before performing any procedure in this chapter.

Failure to follow these instructions will result in death or serious injury.

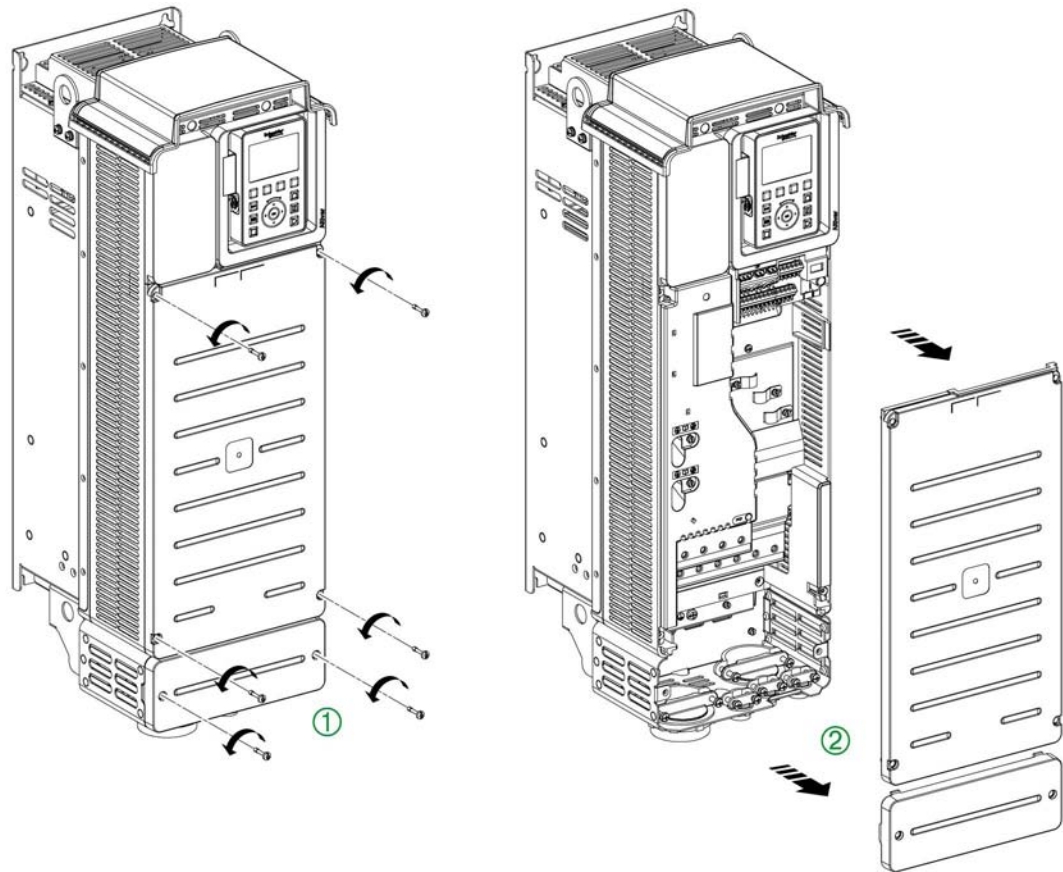

Apply the following instructions to access the terminals on **frame size 4 and 5** drives

Step	Action
1	Unscrew the 6 screws (frame size 4) or the 8 screws (frame size 5) attaching the front and bottom covers
2	Remove the covers

⚠ ⚠ DANGER

HAZARD OF ELECTRIC SHOCK, EXPLOSION OR ARC FLASH

Read and understand the instructions in **Safety Information** chapter before performing any procedure in this chapter.

Failure to follow these instructions will result in death or serious injury.

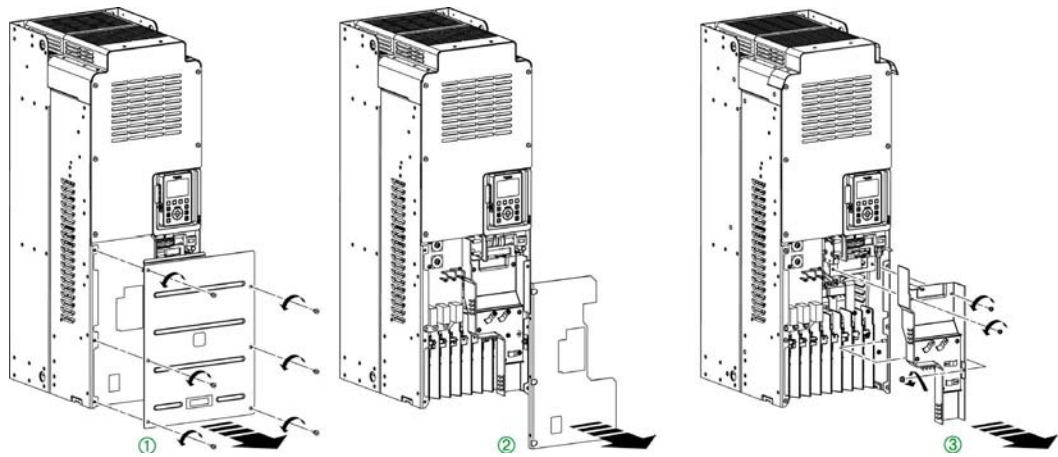

Apply the following instructions to access the terminals on **frame sizes 6** drives

Step	Action
1	Unscrew the 6 screws attaching the bottom front cover and remove it
2	Remove the terminal cover
3	Remove the cable duct

⚡ ⚠ DANGER

HAZARD OF ELECTRIC SHOCK, EXPLOSION OR ARC FLASH

Read and understand the instructions in **Safety Information** chapter before performing any procedure in this chapter.

Failure to follow these instructions will result in death or serious injury.

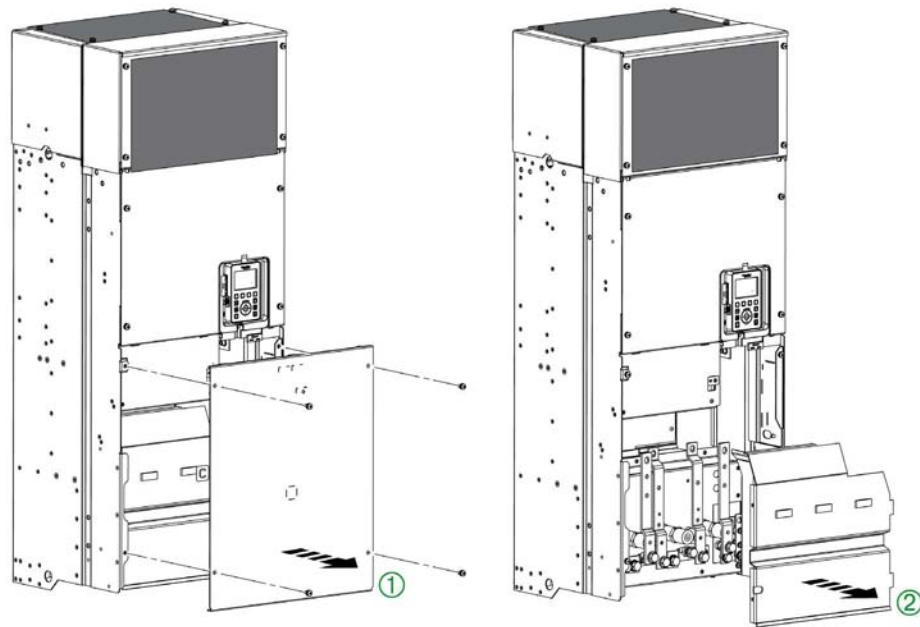

Apply the following instructions to access the terminals on **frame sizes 6** drives

Step	Action
1	Unscrew the 4 screws attaching the bottom front cover and remove it
2	Remove the terminal cover

Access To The Terminals For Frame Size A

⚠ ⚠ DANGER

HAZARD OF ELECTRIC SHOCK, EXPLOSION OR ARC FLASH

Read and understand the instructions in **Safety Information** chapter before performing any procedure in this chapter.

Failure to follow these instructions will result in death or serious injury.

Apply the following instructions to access the terminals on **frame size A** drives

Step	Action
1	Unscrew the 4 captive screws attaching the housing
2	Remove the front cover
3	Attach it on the left or right side of the housing

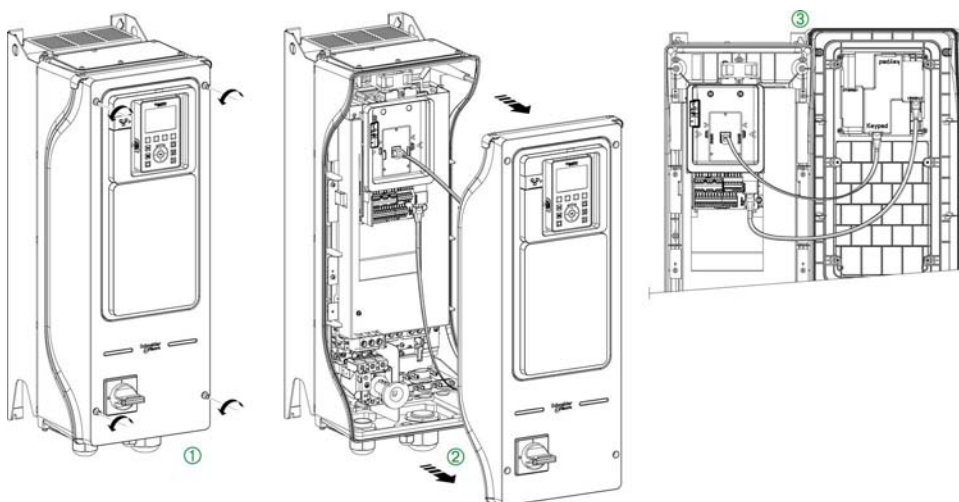

Access To The Terminals For Frame Sizes B and C

DANGER

HAZARD OF ELECTRIC SHOCK, EXPLOSION OR ARC FLASH

Read and understand the instructions in **Safety Information** chapter before performing any procedure in this chapter.

Failure to follow these instructions will result in death or serious injury.

Apply the following instructions to access the terminals on **frame sizes B and C** drives

Step	Action
1	Unscrew the screw attaching the housing
2	Open the front cover

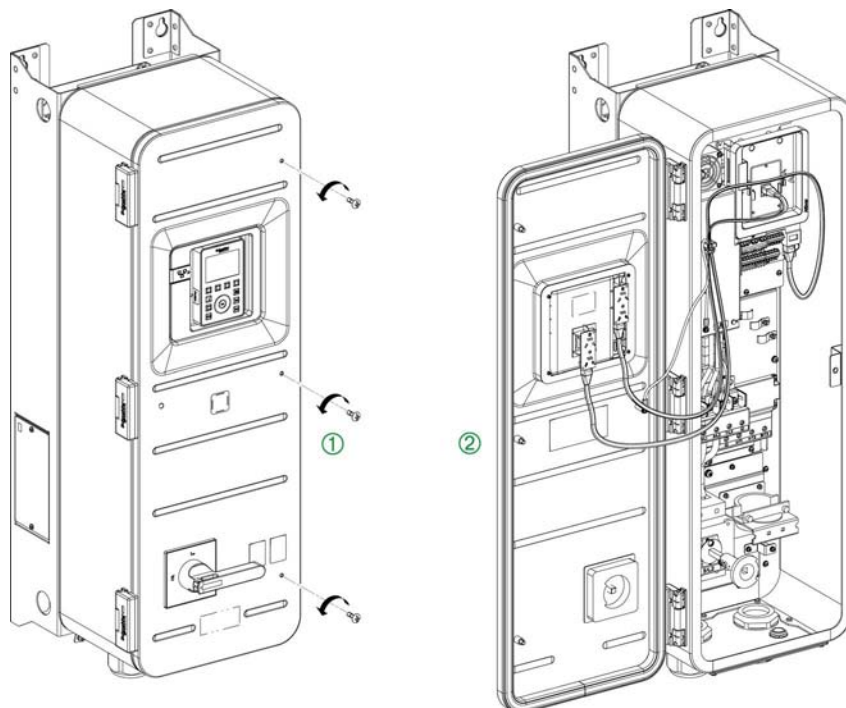

Access To The Terminals - Floor Standing Drives

⚠️ ⚠️ DANGER

HAZARD OF ELECTRIC SHOCK, EXPLOSION OR ARC FLASH

Read and understand the instructions in **Safety Information** chapter before performing any procedure in this chapter.

Failure to follow these instructions will result in death or serious injury.

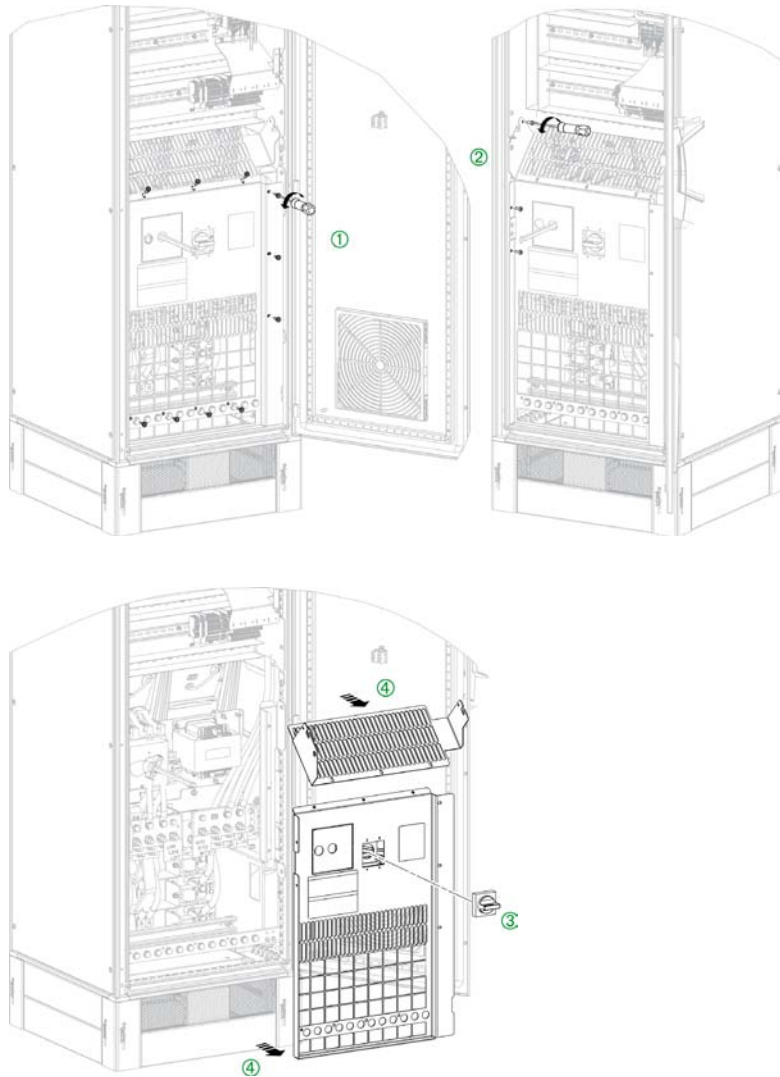

Apply the following instructions to access the terminals on **Floor Standing** drives

Step	Action
1	Open the enclosure. Unscrew the 9 front screws of both upper and lower covers
2	Unscrew the 3 side screws of both upper and lower covers
3	Remove the internal switch handle
4	Remove both upper and lower covers to access the power terminals.

Frame Size 1 Cable Path

Wire the power cables as shown below.

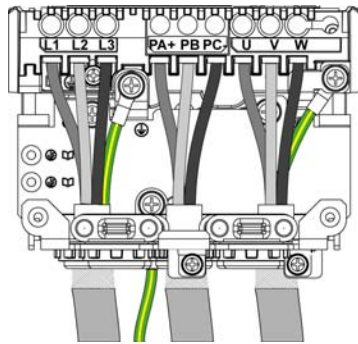

Frame Size 2 Cable Path

Wire the power cables as shown below.

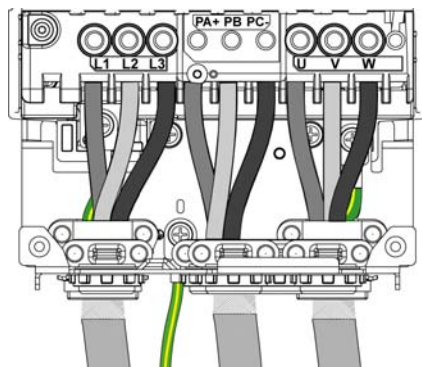

Frame Size 3 Cable Path

Wire the power cables as shown below.

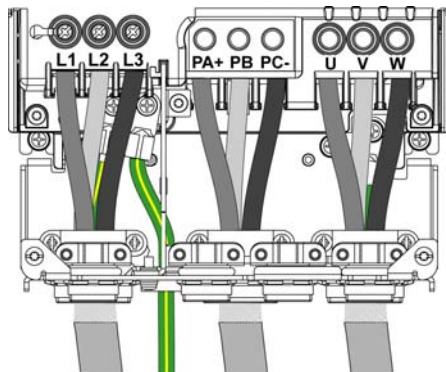

Frame Size 4 and 5 Cable Path

Wire the power cables as shown below.

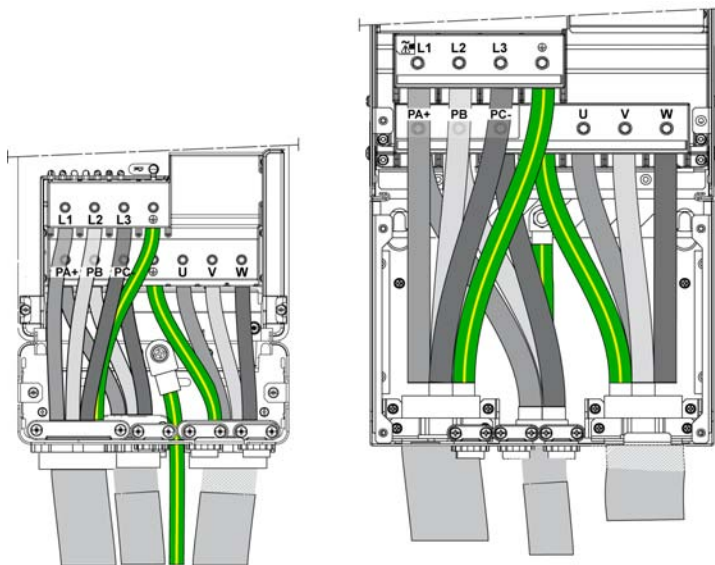

Frame Size 6 Cable Path

Use 1 or 2 connection cables per terminal, depending on the cable characteristics. Refer to standard IEC 60364-5-52 for cable selection. Permissible cable cross sections are given in the Power Terminals section (*see page 99*).

For 2 connection cable wiring:

Step	Action
1	connect the first cable on the lower terminal
2	connect the other cable on the upper terminal

For 2 cable connection, wire the power cables as shown below.

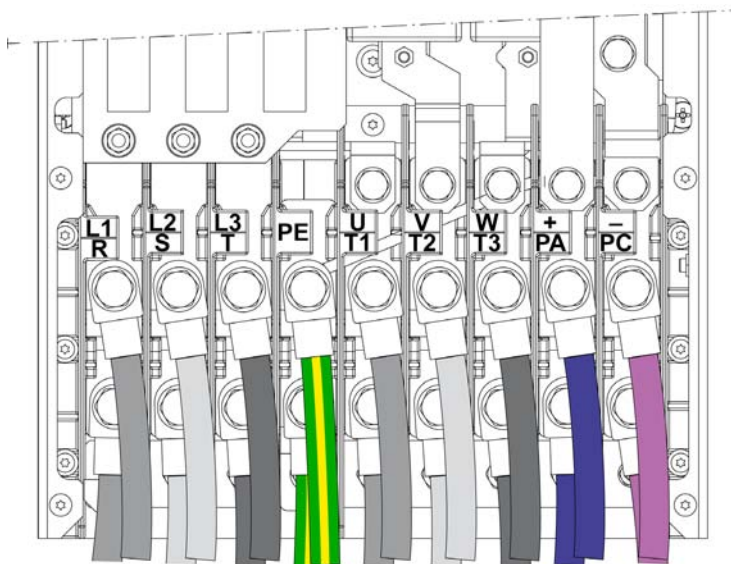

NOTE: A conduit box is available as an option. It enables an IP21 degree of protection at the bottom side of the drive. See www.schneider-electric.com

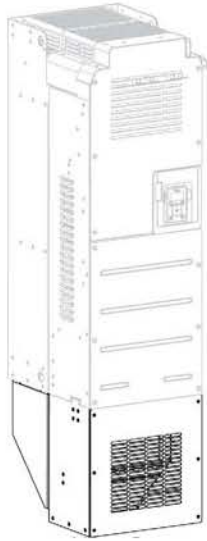

Frame Size 7a Cable Path

Refer to standard IEC 60364-5-52 for cable selection. Permissible cable cross sections are given in the Power Terminals section ([see page 99](#)).

Wire the power cables as shown below.

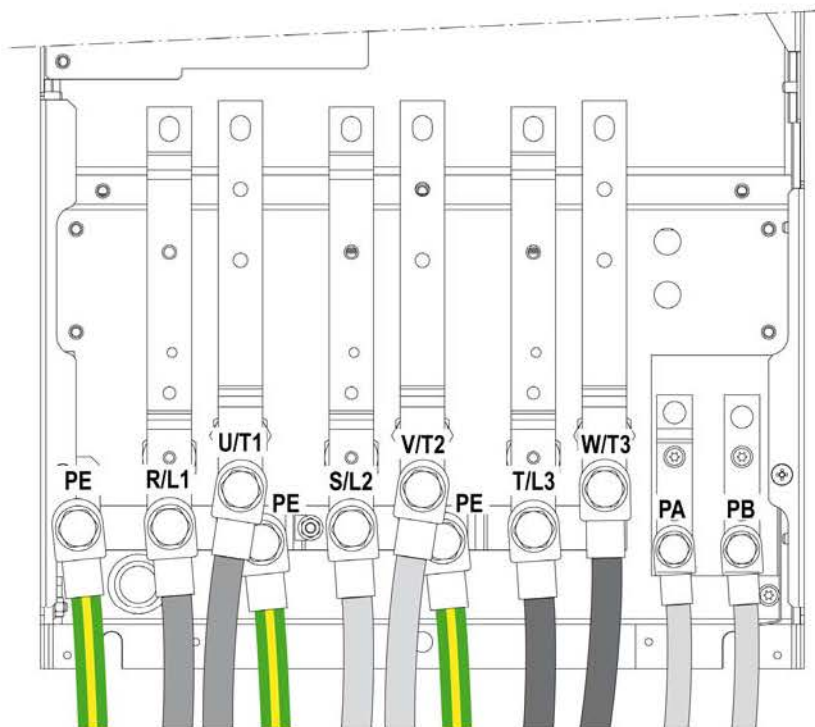
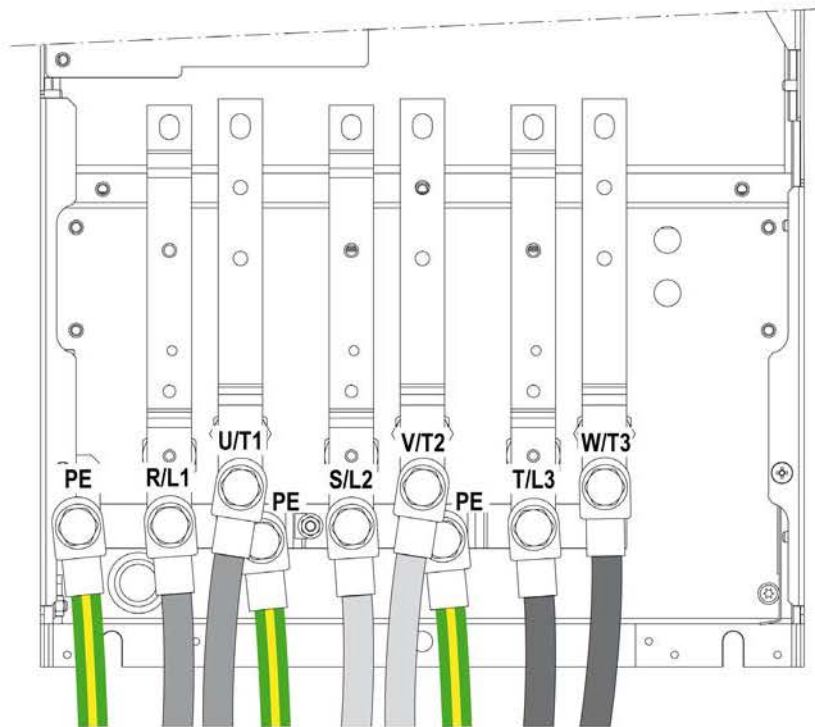

Cable wiring:

Step	Action
1	connect the first cable on the lower terminal
2	connect the other cable on the upper terminal

NOTE: Wiring of the DC chokes is described in the Installing the DC Choke section ([see page 83](#)).

Frame Size 7b Cable Path

Refer to standard IEC 60364-5-52 for cable selection. Permissible cable cross sections are given in the Power Terminals section ([see page 99](#)).

Wire the power cables as shown below.

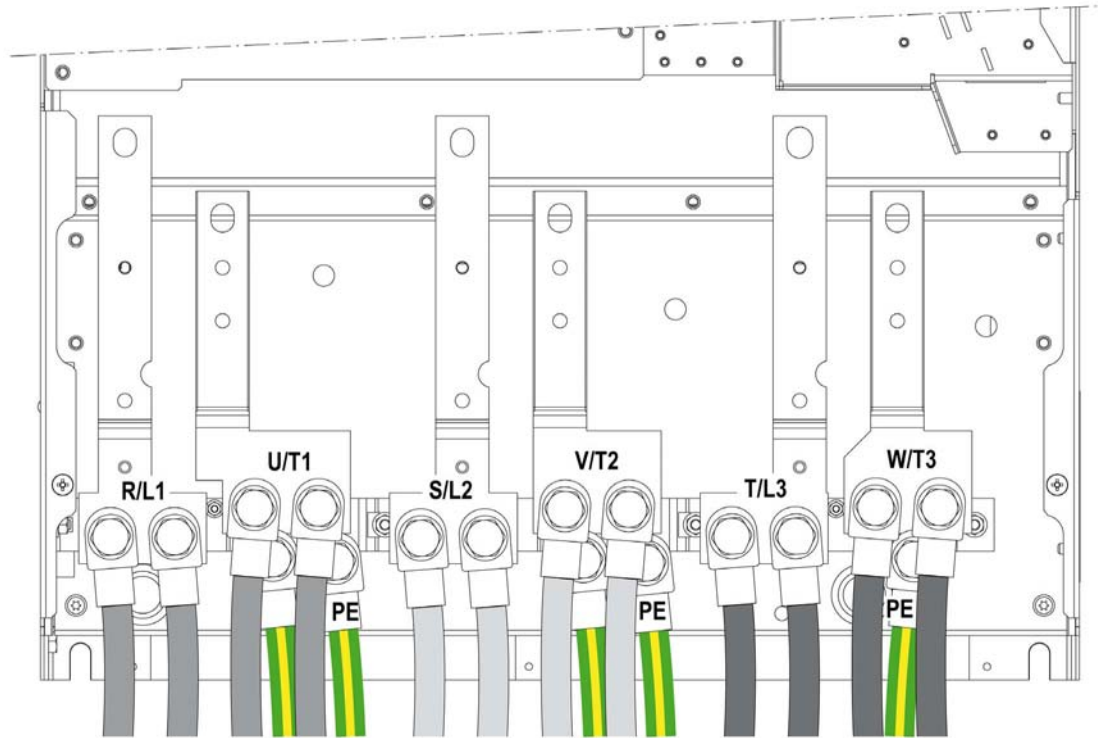

Cable wiring:

Step	Action
1	connect the first cable on the lower terminal
2	connect the other cable on the upper terminal

NOTE: Wiring of the DC chokes is described in the Installing the DC Choke section ([see page 83](#)).

Frame Size 7a and 7b DC Bus terminals

The figures below show where to find DC Bus terminals (PA/+, PC/-) respectively on Frame Size 7a (left) and 7b (right).

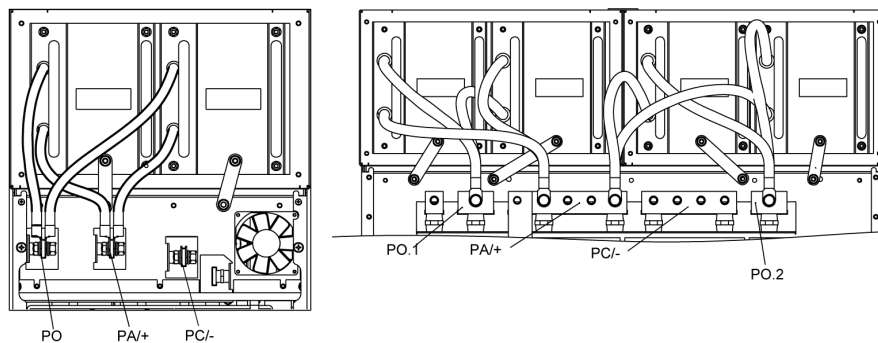

Floor Standing Drives - Wiring Procedure

Permissible cable cross sections and tightening torques are given in the Power Terminals section (see page 99).

NOTE: The cable length from the bottom of the drive to the terminals is between 350 mm (13.8 in.) and 420 mm (16.6 in.), depending on the rank of the terminal.

Perform the following instructions to connect the power part:

Step	Action
1	Verify the input mains supply voltage. The drive transformer is factory set to suit a 380/400 Vac mains supply input voltage. If the supply mains voltage is between 415 and 440 Vac, disconnect P1 transformer terminal and connect the wire to the P2 terminal.
2	Connect the supply mains cable lugs to the power input terminals L1, L2, L3. Attach the PE cable lug to the Ground bar.
3	Connect the motor cable lugs to the power output terminals U, V, W. Attach the PE cable lug to the Ground bar.
4	Position the lower cable clamp on the insulated part of the supply mains cable and attach it to the lower rail. Position the upper cable clamp on the cable shielding of the motor cable and attach it to the upper rail. Position the lower cable clamp on the insulated part of the motor cable and attach it to the lower rail.

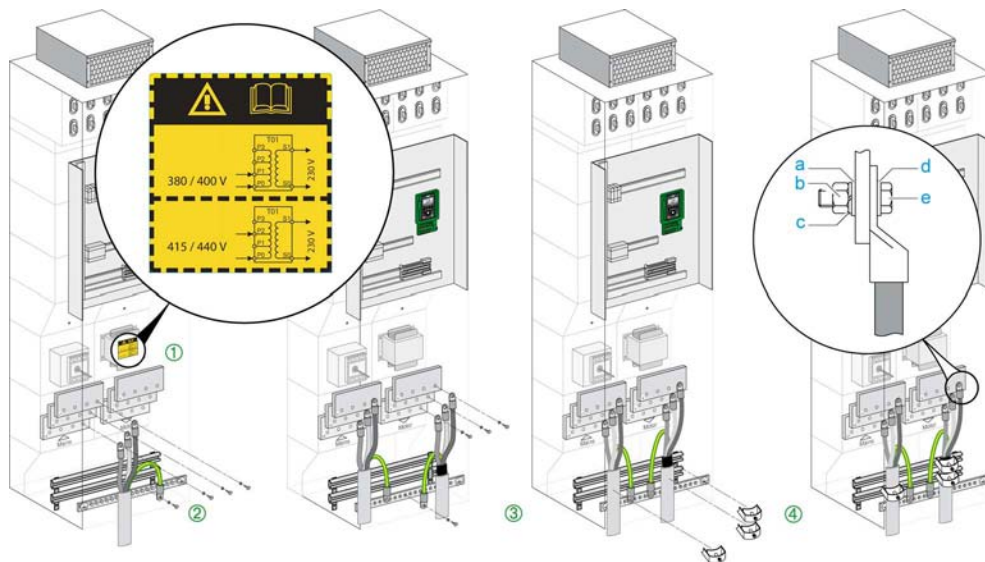

- a flat washer
- b nut
- c spring washer
- d flat washer
- e M12 screw

Electromagnetic Compatibility

Limit Values

This product meets the EMC requirements according to the standard IEC 61800-3 if the measures described in this manual are implemented during installation. If the selected composition (product itself, mains filter, other accessories and measures) does not meet the requirements of category C1, the following information applies as it appears in IEC 61800-3:

⚠ WARNING
RADIO INTERFERENCE
In a domestic environment this product may cause radio interference in which case supplementary mitigation measures may be required.
Failure to follow these instructions can result in death, serious injury, or equipment damage.

EMC requirements for the control cabinet

EMC measures	Objective
Use mounting plates with good electrical conductivity, connect large surface areas of metal parts, remove paint from contact areas.	Good conductivity due to large surface contact.
Ground the control cabinet, the control cabinet door and the mounting plate with ground straps or ground wires. The conductor cross section must be at least 10 mm ² (AWG 8).	Reduces emissions.
Fit switching devices such as power contactors, relays or solenoid valves with interference suppression units or arc suppressors (for example, diodes, varistors, RC circuits).	Reduces mutual interference.
Install power components and control components separately.	
Install frame size 1 and 2 drives on grounded metal back plane.	Reduces emissions.

Shielded cables

EMC measures	Objective
Connect large surface areas of cable shields, use cable clamps and ground straps.	Reduces emissions.
Use cable clamps to connect a large surface area of the shields of all shielded cables to the mounting plate at the control cabinet entry.	
Ground shields of digital signal wires at both ends by connecting them to a large surface area or via conductive connector housings	Reduces interference affecting the signal wires, reduces emissions
Ground the shields of analog signal wires directly at the device (signal input); insulate the shield at the other cable end or ground it via a capacitor (for example, 10 nF, 100 V or higher).	Reduces ground loops due to low-frequency interference.
Use only shielded motor cables with copper braid and a coverage of at least 85%, ground a large surface area of the shield at both ends.	Diverts interference currents in a controlled way, reduces emissions.

Cable Installation

EMC measures	Objective
Do not route fieldbus cables and signal wires in a single cable duct together with lines with DC and AC voltages of more than 60 V. (Fieldbus cables, signal lines and analog lines may be in the same cable duct) Recommendation: Use separate cable ducts at least 20 cm (8 in.) apart.	Reduces mutual interference.
Keep cables as short as possible. Do not install unnecessary cable loops, use short cables from the central grounding point in the control cabinet to the external ground connection.	Reduces capacitive and inductive interference.
Use equipotential bonding conductors in the following cases: wide-area installations, different voltage supplies and installation across several buildings.	Reduces current in the cable shield, reduces emissions.
Use fine stranded equipotential bonding conductors.	Diverts high-frequency interference currents
If motor and machine are not conductively connected, for example by an insulated flange or a connection without surface contact, you must ground the motor with a ground strap or a ground wire. The conductor cross section must be at least 10 mm ² (AWG 8).	Reduces emissions, increases immunity.
Use twisted pair for the DC supply. For digital and analog inputs use shielded twisted cables with a pitch of between 25...50 mm (1...2 in).	Reduces interference affecting the signal cables, reduces emissions.

Power Supply

EMC measures	Objective
Operate product on mains with grounded neutral point.	Enables effectiveness of mains filter.
Surge arrester if there is a risk of overvoltage.	Reduces the risk of damage caused by overvoltage.

Additional measures for EMC improvement

Depending on the application, the following measures can improve the EMC-dependent values:

EMC measures	Objective
Use mains chokes	Reduces mains harmonics, prolongs product service life.
Use external mains filters	Improves the EMC limit values.
Additional EMC measures, for example mounting in a closed control cabinet with 15 dB shielding attenuation of radiated interference	

NOTE: If using an additional input filter, it should be mounted as close as possible to the drive and connected directly to the supply mains via an unshielded cable.

Operation on an IT or Corner Grounded System

Definition

IT system: Isolated or impedance grounded neutral. Use a permanent insulation monitoring device compatible with nonlinear loads, such as an XM200 type or equivalent.

Corner grounded system: System with one phase grounded.

Operation

NOTICE

RISK OF DAMAGE TO THE DRIVE

If the drive is used on an IT or corner grounded system, the built-in EMC filter must be disconnected as described in this manual.

Failure to follow these instructions can result in equipment damage.

Disconnecting The Built-in EMC Filter

Filter Disconnection

DANGER

HAZARD OF ELECTRIC SHOCK, EXPLOSION OR ARC FLASH

Read and understand the instructions in **Safety Information** chapter before performing any procedure in this chapter.

Failure to follow these instructions will result in death or serious injury.

The drives have a built-in EMC filter. As a result they exhibit leakage current to ground. If the leakage current creates compatibility problems with your installation (residual current device or other), then you can reduce the leakage current by disconnecting the built-in filter as shown below. In this configuration the product does not meet the EMC requirements according to the standard IEC 61800-3.

Setting

Apply the following instructions to disconnect the built-in EMC filter.

Step	Action
1	Remove the front cover (see page 106)
2	The screw(s) is/are factory set to the ① position, as shown on detail ①
3	For operation without the built-in EMC filter, remove the screw(s) from its/ their location and set it/them to the ② position, as shown on detail ②
4	Refit the front cover

NOTE:

- Use only the screw(s) supplied.
- Do not operate the drive with setting screw(s) removed.

Setting For Frame Size 1 Products

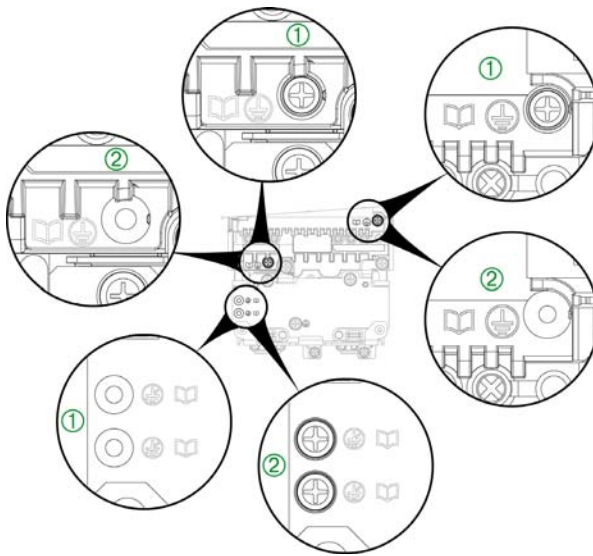

Setting For Frame Size 2, 3 and IP55 Frame Size A Products

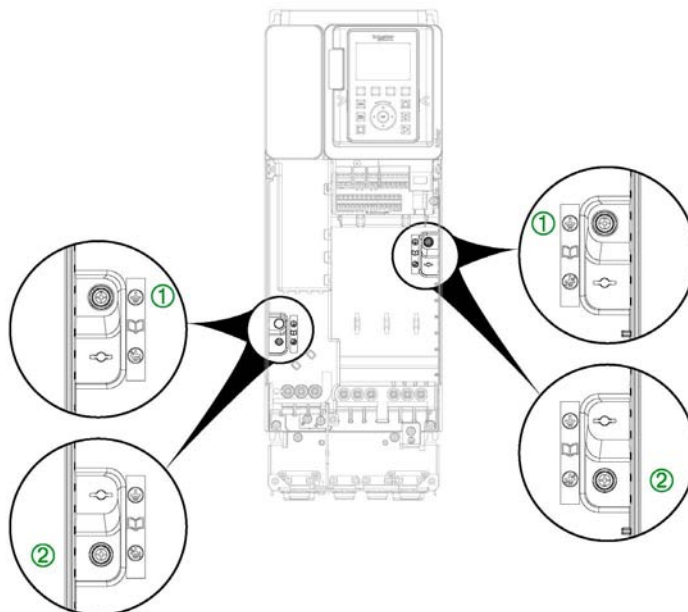

Setting For Frame Size 4 Products

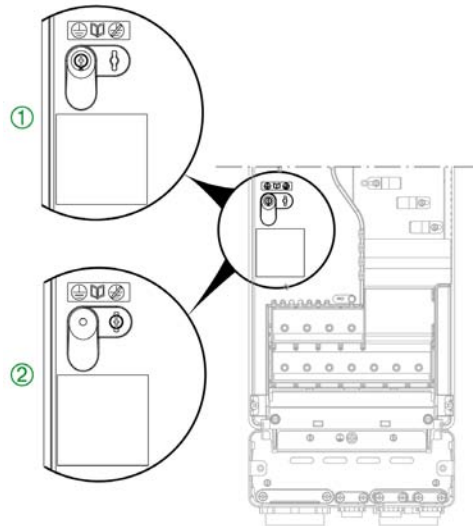

Setting For Frame IP55 Size B Products

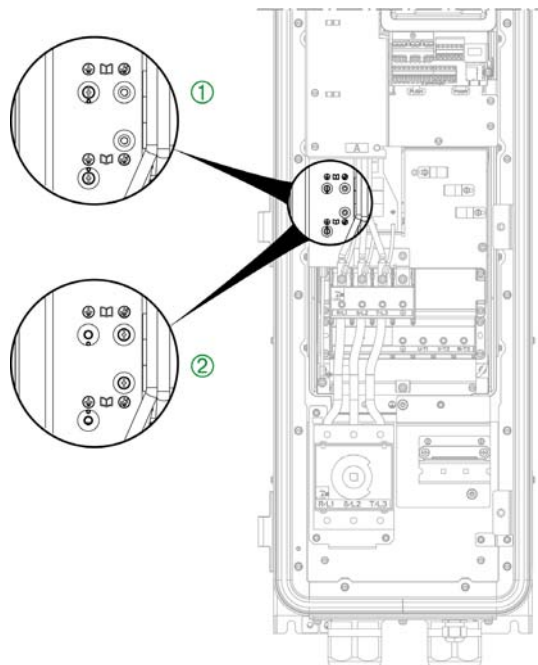

Setting For Frame Size 5 and IP55 Frame Size C Products

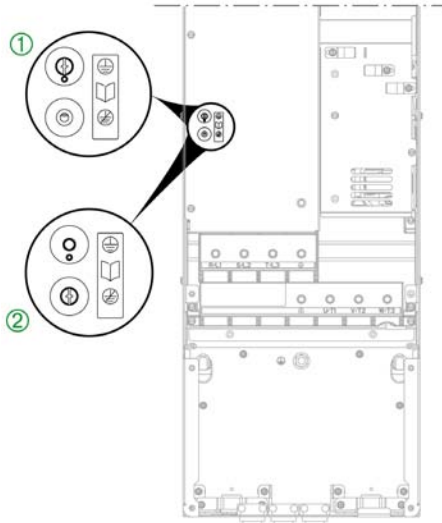

Setting For Frame Size 6 Products

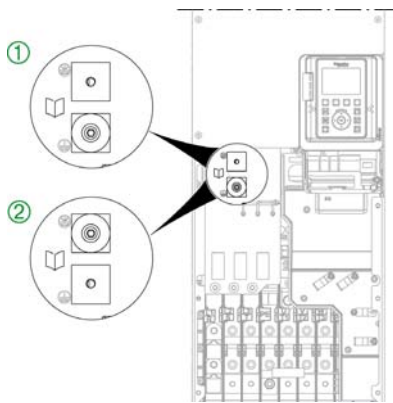

Setting For Frame Size 7A Products

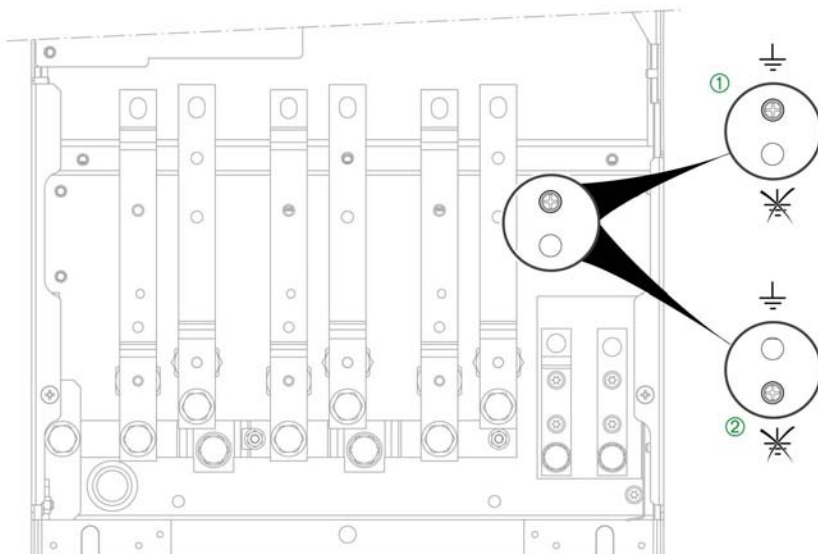

Setting For Frame Size 7B Products

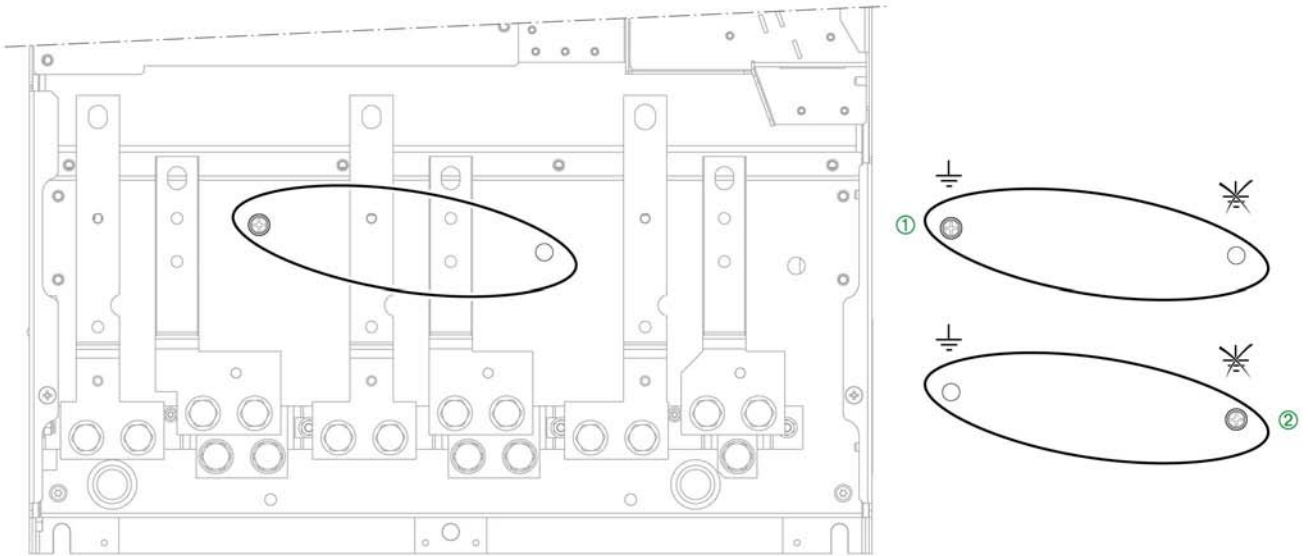

Setting For Floor Standing Products

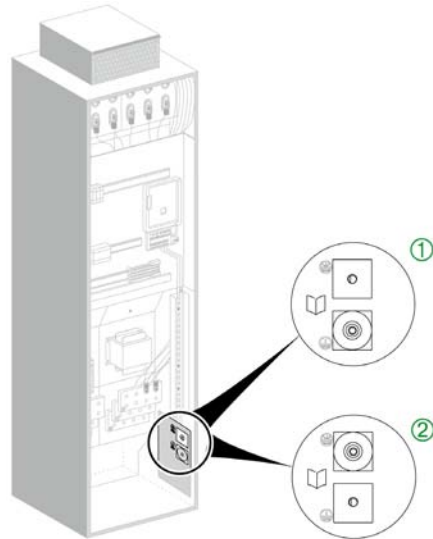

Control Terminals Electrical Data

Characteristics of Terminals

NOTE:

- For a description of the terminal arrangement, refer to Arrangement and Characteristics of Control Terminals and Communication And I/O Ports (*see page 129*)
- For factory setting I/O assignment, refer to the Programming manual [NHA8075Z](#).

Terminal	Description	I/O Type	Electrical characteristics
R1A	NO contact of relay R1	O	Output Relay 1 <ul style="list-style-type: none"> • Minimum switching capacity: 5 mA for 24 Vdc • Maximum switching current on resistive load: ($\cos \phi = 1$): 3 A for 250 Vac (OVC II) and 30 Vdc • Maximum switching current on inductive load: ($\cos \phi = 0.4$ and $L/R = 7$ ms): 2 A for 250 Vac (OVC II) and 30 Vdc • Refresh time: 5 ms +/- 0.5 ms • Service life: 100,000 operations at maximum switching current
R1B	NC contact of relay R1	O	
R1C	Common point contact of relay R1	O	
R2A	NO contact of relay R2	O	Output Relay 2 <ul style="list-style-type: none"> • Minimum switching capacity: 5 mA for 24 Vdc • Maximum switching current on resistive load: ($\cos \phi = 1$): 5 A for 250 Vac and 30 Vdc • Maximum switching current on inductive load: ($\cos \phi = 0.4$ and $L/R = 7$ ms): 2 A for 250 Vac and 30 Vdc • Refresh time: 5 ms +/- 0.5 ms • Service life: <ul style="list-style-type: none"> ○ 100,000 operations at maximum switching power ○ 500,000 operations at 0.5 A for 30 Vdc ○ 1,000,000 operations at 0.5 A for 48 Vac
R2C	Common point contact of relay R2	O	
R3A	NO contact of relay R3	O	Output Relay 3 <ul style="list-style-type: none"> • Minimum switching capacity: 5 mA for 24 Vdc • Maximum switching current on resistive load: ($\cos \phi = 1$): 5 A for 250 Vac and 30 Vdc • Maximum switching current on inductive load: ($\cos \phi = 0.4$ and $L/R = 7$ ms): 2 A for 250 Vac and 30 Vdc • Refresh time: 5 ms +/- 0.5 ms • Service life: <ul style="list-style-type: none"> ○ 100,000 operations at maximum switching power ○ 500,000 operations at 0.5 A for 30 Vdc ○ 1,000,000 operations at 0.5 A for 48 Vac
R3C	Common point contact of relay R3	O	
$\overline{\text{STOA}}$, $\overline{\text{STOB}}$	STO inputs	I	Safety Function STO Inputs Refer to the ATV900 Embedded Safety Function manual NHA8094Z available on www.schneider-electric.com
24V	Output power supply for digital inputs and safety function STO inputs	O	<ul style="list-style-type: none"> • +24 Vdc • Tolerance: minimum 20.4 Vdc, maximum 27 Vdc • Current: maximum 200 mA for both 24 Vdc terminals • Terminal protected against overload and short-circuit • In Sink Ext position, this supply is powered by external PLC supply
10V	Output supply for Analog input	O	Internal supply for the analog inputs <ul style="list-style-type: none"> • 10.5 Vdc • Tolerance $\pm 5\%$ • Current: maximum 10 mA • Short circuit protected

Terminal	Description	I/O Type	Electrical characteristics
AI1-AI3	Analog inputs and sensor inputs	I	<p>Software-configurable V/A : voltage or current analog input</p> <ul style="list-style-type: none"> ● Voltage analog input 0...10 Vdc, impedance 31.5 kΩ, ● Current analog input X-Y mA by programming X and Y from 0...20 mA, with impedance 250 Ω ● Maximum sampling time: 1 ms \pm 1 ms ● Resolution 12 bits ● Accuracy: \pm 0.6% for a temperature variation of 60°C (140°F) ● Linearity \pm 0.15% of maximum value <p>Software-configurable thermal sensors or Water level sensor</p> <ul style="list-style-type: none"> ● PT100 <ul style="list-style-type: none"> ○ 1 or 3 thermal sensors mounted in series (configurable by software) ○ Sensor current: 5 mA maximum ○ Range -20...200°C (-4...392°F) ○ Accuracy +/- 4°C (39°F) for a temperature variation of 60°C (140°F) ● PT1000 <ul style="list-style-type: none"> ○ 1 or 3 thermal sensors mounted in series (configurable by software) ○ Sensor current: 1 mA ○ Range -20...200°C (-4...392°F) ○ Accuracy +/- 4°C (39°F) for a temperature variation of 60°C (140°F) ● KTY84 <ul style="list-style-type: none"> ○ 1 thermal sensor ○ Sensor current: 1 mA ○ Range -20...200°C (-4...392°F) ○ Accuracy \pm 4°C (39°F) for a temperature variation of 60°C (140°F) ● PTC <ul style="list-style-type: none"> ○ 6 sensors maximum mounted in series ○ Sensor current: 1 mA ○ Nominal value: < 1.5 kΩ ○ Overheat trigger threshold: 2.9 kΩ \pm 0.2 kΩ ○ Overheat reset threshold: 1.575 kΩ \pm 0.75 kΩ ○ Threshold for low impedance detection: 50 kΩ -10 Ω/+20 Ω ○ Protected for low impedance < 1000 Ω
COM	Analog I/O common	I/O	0 V for Analog outputs
AI2	Analog input	I	<p>Voltage bipolar analog input -10...10 Vdc, impedance 31.5 kΩ</p> <ul style="list-style-type: none"> ● Maximum sampling time: 1 ms \pm 1 ms ● Resolution 12 bits ● Accuracy: \pm 0.6% for a temperature variation of 60°C (140°F) ● Linearity \pm 0.15% of maximum value
AQ1	Analog output	O	<p>AQ: Analog output software-configurable for voltage or current</p> <ul style="list-style-type: none"> ● Voltage analog output 0...10 Vdc, minimum. Minimum load impedance 470 Ω, ● Current analog output X-Y mA by programming X and Y from 0...20 mA, maximum load impedance 500 Ω ● Maximum sampling time: 5 ms \pm 1 ms ● Resolution 10 bits ● Accuracy: \pm 1% for a temperature variation of 60°C (140°F) ● Linearity \pm 0.2%
AQ2	Analog output	O	
COM	Digital and analog output Common	I/O	0 V for analog outputs and logic output
DQ-	Digital output	O	<p>Digital output configurable by switch</p> <ul style="list-style-type: none"> ● Insulated ● Maximum voltage: 30 Vdc ● Maximum current: 100 mA ● Frequency range: 0...1 kHz ● Positive/Negative logic is managed by user external wiring.
DQ+	Digital output	O	

Terminal	Description	I/O Type	Electrical characteristics
DQ+	Pulse output	O	Pulse train output configurable by switch <ul style="list-style-type: none"> ● Open collector not insulated ● Maximum voltage: 30 Vdc ● Maximum current: 20 mA ● Frequency range: 0...30 kHz
P24	External input supply	I	+24 Vdc external input supply <ul style="list-style-type: none"> ● Tolerance: minimum 19 Vdc, maximum 30 Vdc ● Maximum current: 0.8 A
0V	0 V	I/O	0 V of P24
DI1-DI8	Digital inputs	I	8 programmable logic inputs 24 Vdc, comply with IEC/EN 61131-2 logic type 1 <ul style="list-style-type: none"> ● Positive logic (Source): State 0 if ≤ 5 Vdc or logic input not wired, state 1 if ≥ 11 Vdc ● Negative logic (Sink): State 0 if ≥ 16 Vdc or logic input not wired, state 1 if ≤ 10 Vdc ● Impedance 3.5 kΩ ● Maximum voltage: 30 Vdc ● Maximum sampling time: 2 ms \pm 0.5 ms Multiple assignment makes it possible to configure several functions on one input (example: DI1 assigned to forward and preset speed 2, DI3 assigned to reverse and preset speed 3).
DI7-DI8	Pulse inputs	I	Programmable Pulse input <ul style="list-style-type: none"> ● Comply with level 1 PLC, IEC 65A-68 standard ● State 0 if < 0.6 Vdc, state 1 if > 2.5 Vdc ● Pulse counter 0...30 kHz ● Frequency range: 0...30 kHz ● Cyclic ratio: 50 % \pm 10 % ● Maximum input voltage 30 Vdc, < 10 mA ● Maximum sampling time: 5 ms \pm 1 ms

Arrangement and Characteristics of Control Block Terminals and Communication and I/O Ports

Terminal Arrangement

The control block terminals are the same for all drive frame sizes.

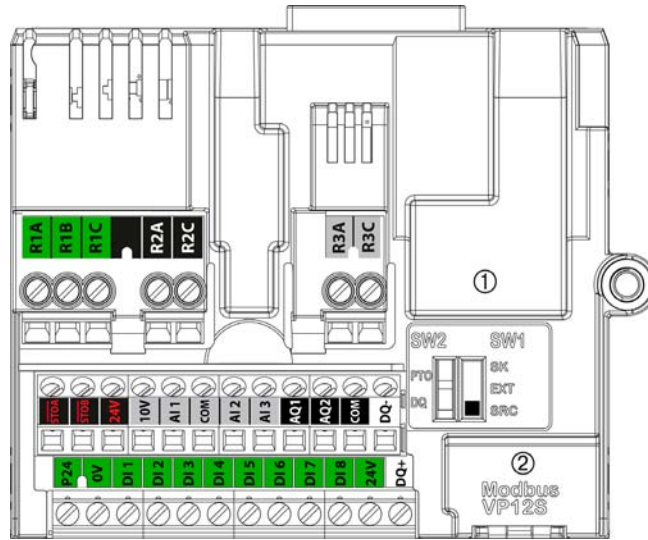

① Ethernet Modbus TCP, ② Serial Modbus

NOTE: Modbus VP12S: This is the standard Modbus serial link marking. VP•S means connector with power supply, where 12 stands for the 12 Vdc supply voltage.

Wiring Characteristics

Wire cross sections and tightening torques

Control Terminals	Relay Output Wire Cross Section		Other Wire Cross Section		Tightening Torque
	Minimum (1)	Maximum	Minimum (1)	Maximum	
	mm ² (AWG)	mm ² (AWG)	mm ² (AWG)	mm ² (AWG)	
All terminals	0.75 (18)	1.5 (16)	0.5 (20)	1.5 (16)	0.5 (4.4)

(1) The value corresponds to the minimum permissible cross section of the terminal.

NOTE: Also refer to Control Terminal Electrical data ([see page 126](#)).

Control Block Ports

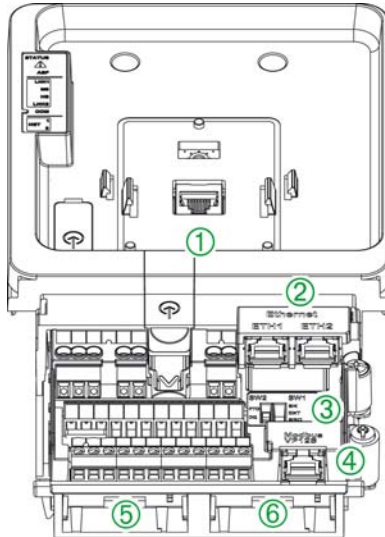

Legend

Marking	Description
①	RJ45 port for Graphic display terminal
②	RJ45 ports for Ethernet embedded
③	Sink-Ext-Source switch (<i>see page 97</i>) PTO-DQ switch (<i>see page 98</i>)
④	RJ45 port for Modbus embedded
⑤	Slot B, for encoder interface, and I/O relay module
⑥	Slot A, for communication and I/O relay modules

RJ45 Communication ports

The control block includes 4 RJ45 ports.

They allow to connect:

- A PC
 - Using a commissioning software (SoMove, SoMachine...), to configure and monitor the drive
 - To access the drive webserver
- A SCADA system
- A PLC system
- A Graphic Display terminal, using Modbus protocol
- A Modbus fieldbus

NOTE: Verify that RJ45 cable is not damaged prior to connect it to the product otherwise the power supply of the control could be lost.

NOTE: Do not plug Ethernet cable in Modbus plug or vice versa.

Wiring The Control Part

Preliminary Steps

⚡ ⚠ DANGER

HAZARD OF ELECTRIC SHOCK, EXPLOSION OR ARC FLASH

Read and understand the instructions in **Safety Information** chapter before performing any procedure in this chapter.

Failure to follow these instructions will result in death or serious injury.

⚠ WARNING

UNINTENDED BEHAVIOR OF INPUTS AND OUTPUTS

The functions of the inputs and outputs depend on the selected operating mode and the settings of the corresponding parameters.

- Verify that the wiring is appropriate for the settings.
- Only start the system if there are no persons or obstructions in the hazardous area.
- When commissioning, carefully run tests for all operating states and potential error situations.

Failure to follow these instructions can result in death, serious injury, or equipment damage.

Optional Module Installation and Wiring

Apply the following instructions to install and connect a module to be wired

Step	Action
1	Insert the module in the slot A or B (<i>see page 130</i>).
2	Insert the cable in the cabling plate, according to the outlined locations. The breakable cut out is used for fieldbus cables.
3	Connect the cable to the module

(Procedure applicable for wall mounting product)

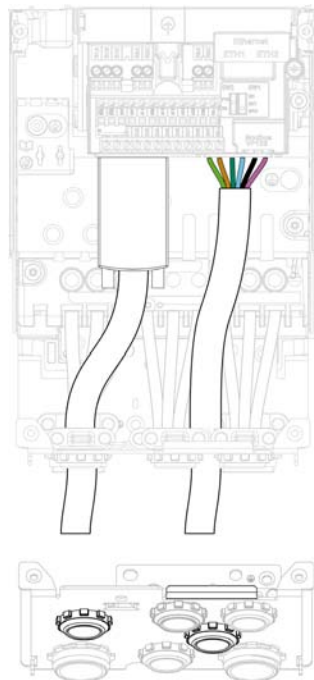

NOTE: Cabling plate shown is for frame size 2. Other cabling plates look slightly differs from this one.

NOTE: For Floor standing products route the option cables into the integrated control cable conduit.

Encoder Interface Module Installation and Wiring

Apply the following instructions to install the encoder interface module

Step	Action
1	Insert the encoder interface module in the slot B (<i>see page 130</i>) and push it to its final position until you hear a “click” sound
2	Insert the cable in the cabling plate, according to the outlined location.
3	Wire the SUB-D connector
4	Plug the SUB-D connector on the option module

(Procedure applicable for wall mounting product)

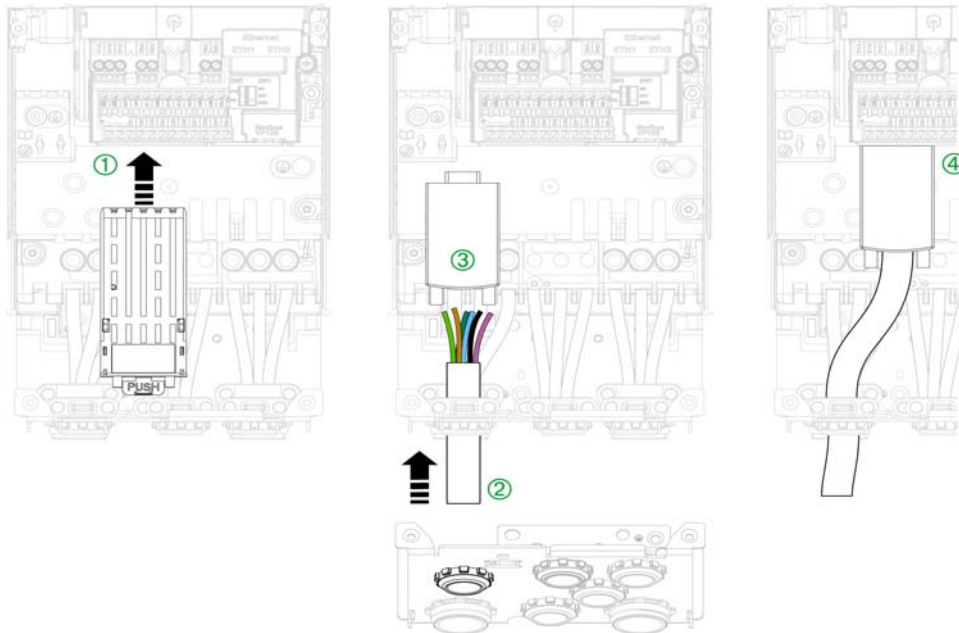

NOTE: Cabling plate shown is for frame size 2. Other cabling plates look slightly differs from this one.

NOTE: For Floor standing products route the option cables into the integrated control cable conduit.

I/O Relay Module Installation and Wiring

Apply the following instructions to install an I/O relay module

Step	Action
1	Insert the I/O relay module in an option slot
2	Push the module into its location and keep access to the module terminal screws
3	Insert the I/O cable in the cabling plate, according to the outlined location
4	Wire the I/O relay module
5	Push again the module to its final position.

(Procedure applicable for wall mounting product)

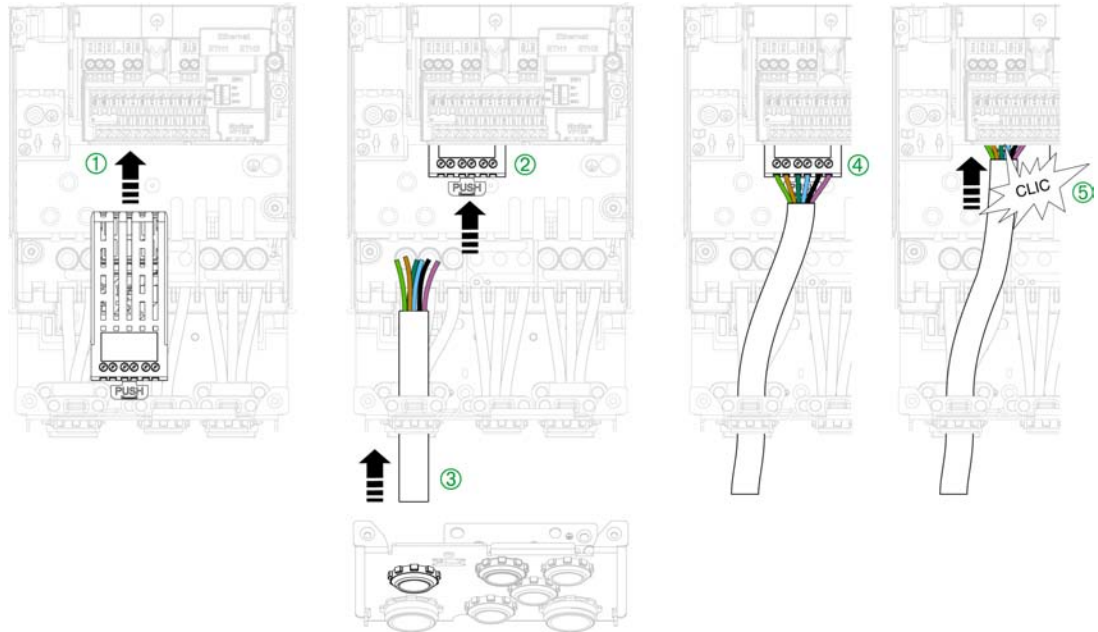

NOTE: Cabling plate shown is for frame size 2. Other cabling plates look slightly differs from this one.

NOTE: For Floor standing products route the option cables into the integrated control cable conduit.

Special Case of PROFIBUS Fieldbus Module Installation and Wiring on Frame Size 1 Drives

Apply the following instructions to install the PROFIBUS fieldbus module on Frame size 1 drives

Step	Action
1	Insert the module in its slot
2	Insert the SUB-D connector in the cut out of the cabling plate
3	Plug the SUB-D connector to the module

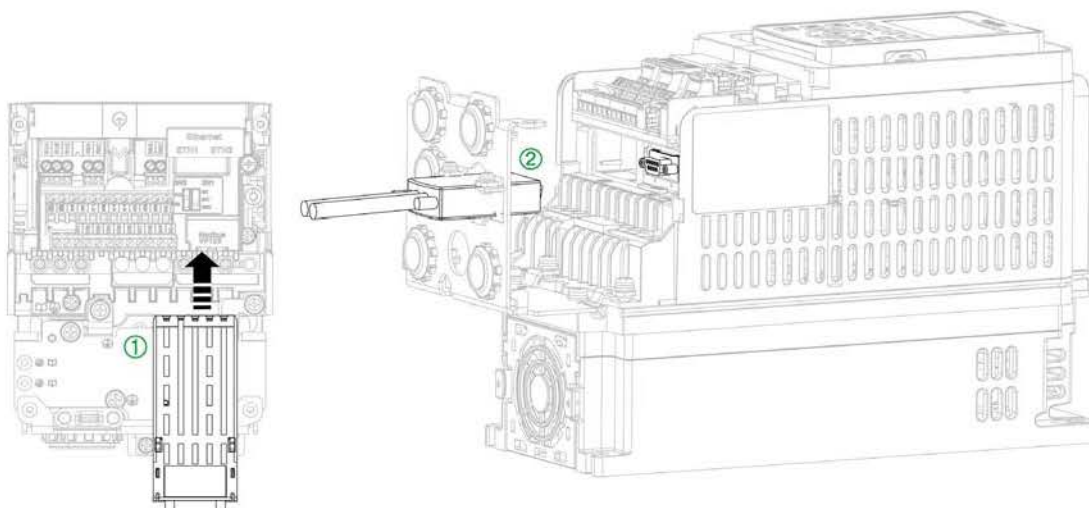

Control Block Wiring

Apply the following instructions to wire the control block terminals

Step	Action
1	Wire the P24, 0V, the digital inputs (DI1...DI8), the 24V and DQ+ terminals
2	Wire the safety outputs STOA, STOB, the 24V, the 10V, the analog inputs (AI1...AI3), the COM, The digital inputs AQ1, AQ2, the COM and DQ- terminals
3	Wire the Relay outputs

(Procedure applicable for wall mounting product)

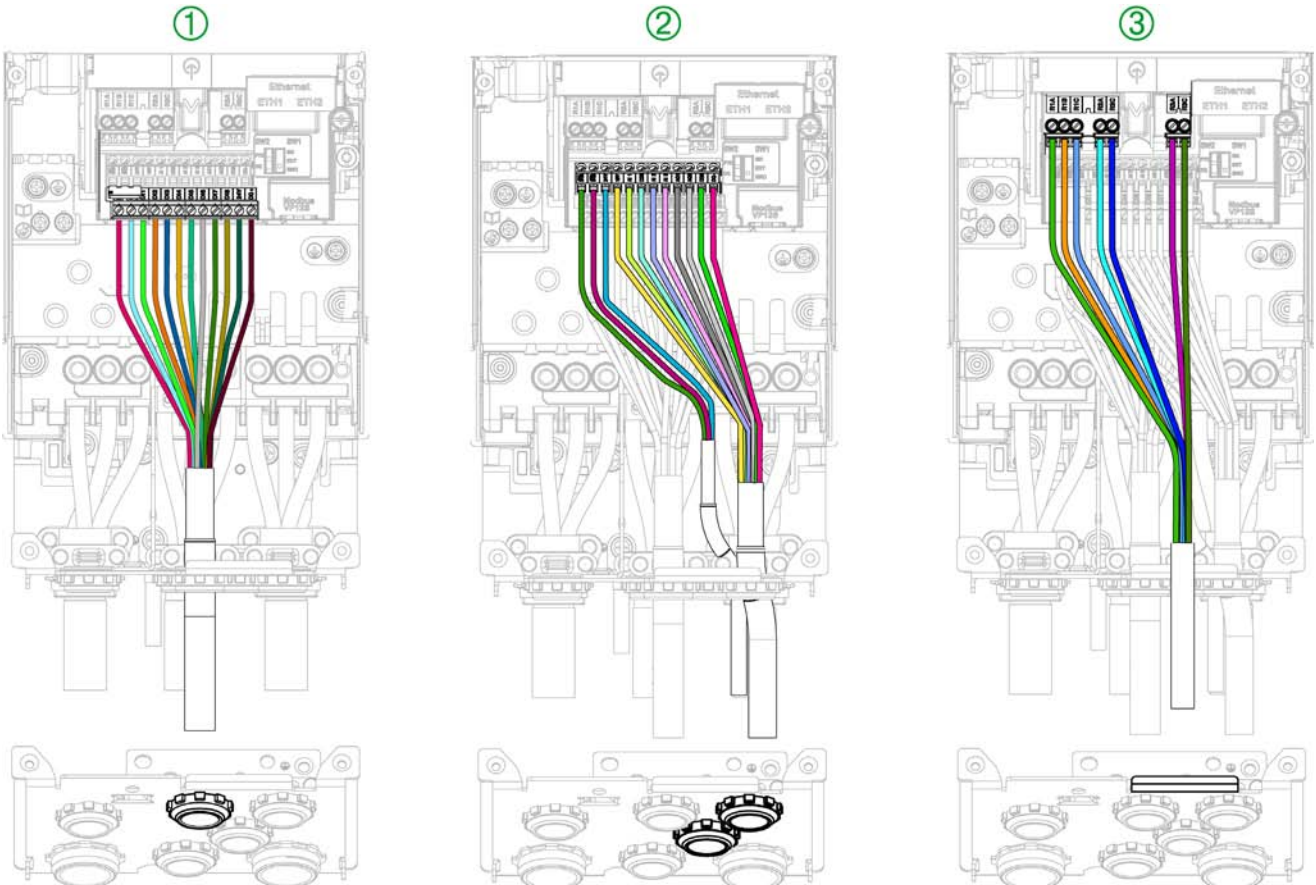

NOTE: Cabling plate shown is for frame size 2. Other cabling plates look slightly differs from this one.

NOTE: For Floor standing products route the control wires into the integrated control cable conduit.

Chapter 5

Checking Installation

Before Switching On

Unsuitable settings or unsuitable data or unsuitable wiring may trigger unintended movements, trigger signals, damage parts and disable monitoring functions.

 WARNING
UNANTICIPATED EQUIPMENT OPERATION <ul style="list-style-type: none">• Only start the system if there are no persons or obstructions in the zone of operation.• Verify that a functioning emergency stop push-button is within reach of all persons involved in the operation.• Do not operate the drive system with unknown settings or data.• Verify that the wiring is appropriate for the settings.• Never modify a parameter unless you fully understand the parameter and all effects of the modification.• When commissioning, carefully run tests for all operating states, operating conditions and potential error situations.• Anticipate movements in unintended directions or oscillation of the motor. Failure to follow these instructions can result in death, serious injury, or equipment damage.

If the power stage is disabled unintentionally, for example as a result of power outage, errors or functions, there is a possibility that the motor is no longer decelerated in a controlled way.

 WARNING
UNANTICIPATED EQUIPMENT OPERATION <p>Verify that movements without braking effect cannot cause injuries or equipment damage.</p> Failure to follow these instructions can result in death, serious injury, or equipment damage.

Mechanical Installation

Verify the mechanical installation of the entire drive system:

Step	Action	<input checked="" type="checkbox"/>
1	Does the installation meet the specified distance requirements?	<input type="checkbox"/>
2	Did you tighten all fastening screws with the specified tightening torque?	<input type="checkbox"/>

Electrical installation

Verify the electrical connections and the cabling:

Step	Action	✓
1	Did you connect all protective ground conductors?	
2	Do all fuses and circuit breaker have the correct rating; are the fuses of the specified type? (refer to the information provided in the Altivar Process ATV900 Getting Started Annex (SCCR) reference: NHA61584).	
3	Did you connect or insulate all wires at the cable ends?	
4	Did you properly connect and install all cables and connectors?	
5	Did you properly connect the signal wires?	
6	Are the required shield connections EMC-compliant?	
7	Did you take all measures for EMC compliance?	
8	On floor standing products, verify that internal circuit breaker is closed	

Covers And Seals

Verify that all devices, doors and covers of cabinet are properly installed to meet the required degree of protection.

Chapter 6

Maintenance

Scheduled servicing

Servicing

DANGER

HAZARD OF ELECTRIC SHOCK, EXPLOSION OR ARC FLASH

Read and understand the instructions in **Safety Information** chapter before performing any procedure in this chapter.

Failure to follow these instructions will result in death or serious injury.

The temperature of the products described in this manual may exceed 80 °C (176 °F) during operation.

WARNING

HOT SURFACES

- Ensure that any contact with hot surfaces is avoided.
- Do not allow flammable or heat-sensitive parts in the immediate vicinity of hot surfaces.
- Verify that the product has sufficiently cooled down before handling it.
- Verify that the heat dissipation is sufficient by performing a test run under maximum load conditions.

Failure to follow these instructions can result in death, serious injury, or equipment damage.

NOTICE

RISK OF DAMAGE TO THE DRIVE

Perform the following activities.

Failure to follow these instructions can result in equipment damage.

Environment	Part concerned	Action	Periodicity (1)
Knock on the product	Housing - control block (led - display, if any)	Verify the drive visual aspect	At least each year
Corrosion	Terminals - connector - screws - EMC plate	Inspect and clean if required	
Dust	Terminals - fans - blowholes - enclosures air inlets and outlets - cabinets air filters	Inspect and clean if required	
	Floor standing drives filter mats	Inspect Change	At least each year At least each 4 years
Temperature	Around the product	Verify and correct if required	
Cooling	Wall mounting drives fan	Verify the fan operation	At least each year
		Replace the fan, see catalog and the instructions sheets on www.schneider-electric.com .	After 3 to 5 years, depending on the operating conditions
	Floor standing drives fan for power part and enclosure door fan	Replace the fans, see catalog and the instructions sheets on www.schneider-electric.com .	Every 35000 operating hours or every 6 years
Vibration		Verify tightening torques	At least each year

(1) As from the date of commissioning. The maintenance intervals really necessary depend on the ambient conditions.

NOTE: The fan operation depends of the drive thermal state. The drive may be running and the fan not.

Specific information applies to the floor standing drives.

Fans may continue to run for a certain period of time even after power to the product has been disconnected.

CAUTION

RUNNING FANS

Verify that fans have come to a complete standstill before handling them.

Failure to follow these instructions can result in injury or equipment damage.

Diagnostic And Troubleshooting

Refer to the Programming Manual [EAV64387](#) available on www.schneider-electric.com.

Spares and repairs

Serviceable product. Please refer to your Customer Care Center.

Long time storage

If the drive was not connected to mains for an extended period of time, the capacitors must be restored to their full performance before the motor is started.

NOTICE

REDUCED CAPACITOR PERFORMANCE

- Apply mains voltage to the drive for one hour before starting the motor if the drive has not been connected to mains for the following periods of time:
 - 12 months at a maximum storage temperature of +50°C (+122°F)
 - 24 months at a maximum storage temperature of +45°C (+113°F)
 - 36 months at a maximum storage temperature of +40°C (+104°F)
- Verify that no Run command can be applied before the period of one hour has elapsed.
- Verify the date of manufacture if the drive is commissioned for the first time and run the specified procedure if the date of manufacture is more than 12 months in the past.

Failure to follow these instructions can result in equipment damage.

If the specified procedure cannot be performed without a Run command because of internal mains contactor control, perform this procedure with the power stage enabled, but the motor being at standstill so that there is no appreciable mains current in the capacitors.



E

Error

Discrepancy between a detected (computed, measured, or signaled) value or condition and the specified or theoretically correct value or condition.

F

Factory setting

Factory settings when the product is shipped

Fault

Fault is an operating state. If the monitoring functions detect an error, a transition to this operating state is triggered, depending on the error class. A "Fault reset" is required to exit this operating state after the cause of the detected error has been removed. Further information can be found in the pertinent standards such as IEC 61800-7, ODVA Common Industrial Protocol (CIP).

Fault Reset

A function used to restore the drive to an operational state after a detected error is cleared by removing the cause of the error so that the error is no longer active.

P

PELV

Protective Extra Low Voltage, low voltage with isolation. For more information: IEC 60364-4-41

PLC

Programmable logic controller

Power stage

The power stage controls the motor. The power stage generates current for controlling the motor.

PTC thermistor

positive temperature coefficient thermistor

W

Warning

If the term is used outside the context of safety instructions, a warning alerts to a potential problem that was detected by a monitoring function. A warning does not cause a transition of the operating state.

